

TRACTION BELT. Poor traction; check traction belt for alignment and tension; worn sprockets or flipped bogies.

CLUTCH. Automatic clutch fails to engage at proper RPM's: Mark IV, 2000 to 2400 RPM; Mark V, 2100 to 2500 RPM. Check variable-speed drive belt for proper tension and alignment.

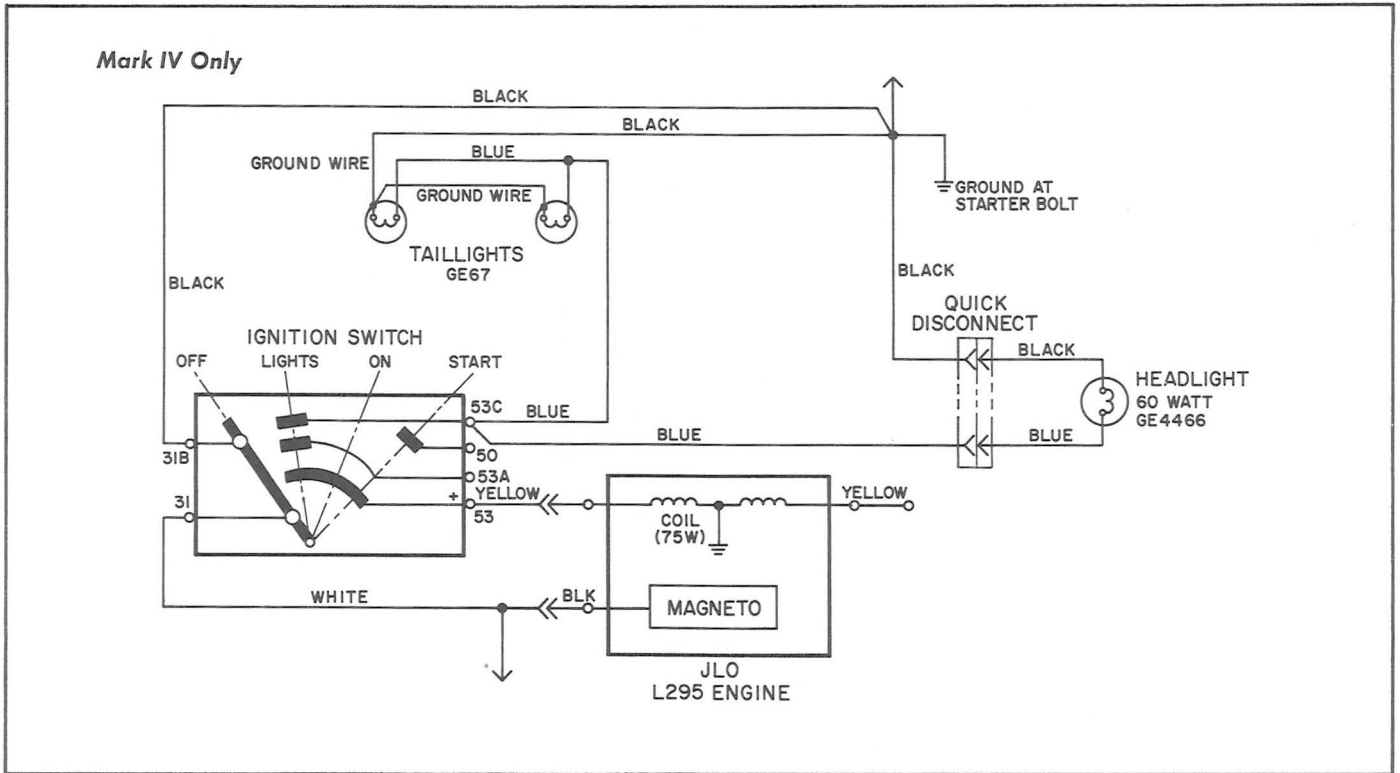

Figure 17

Mark V Only

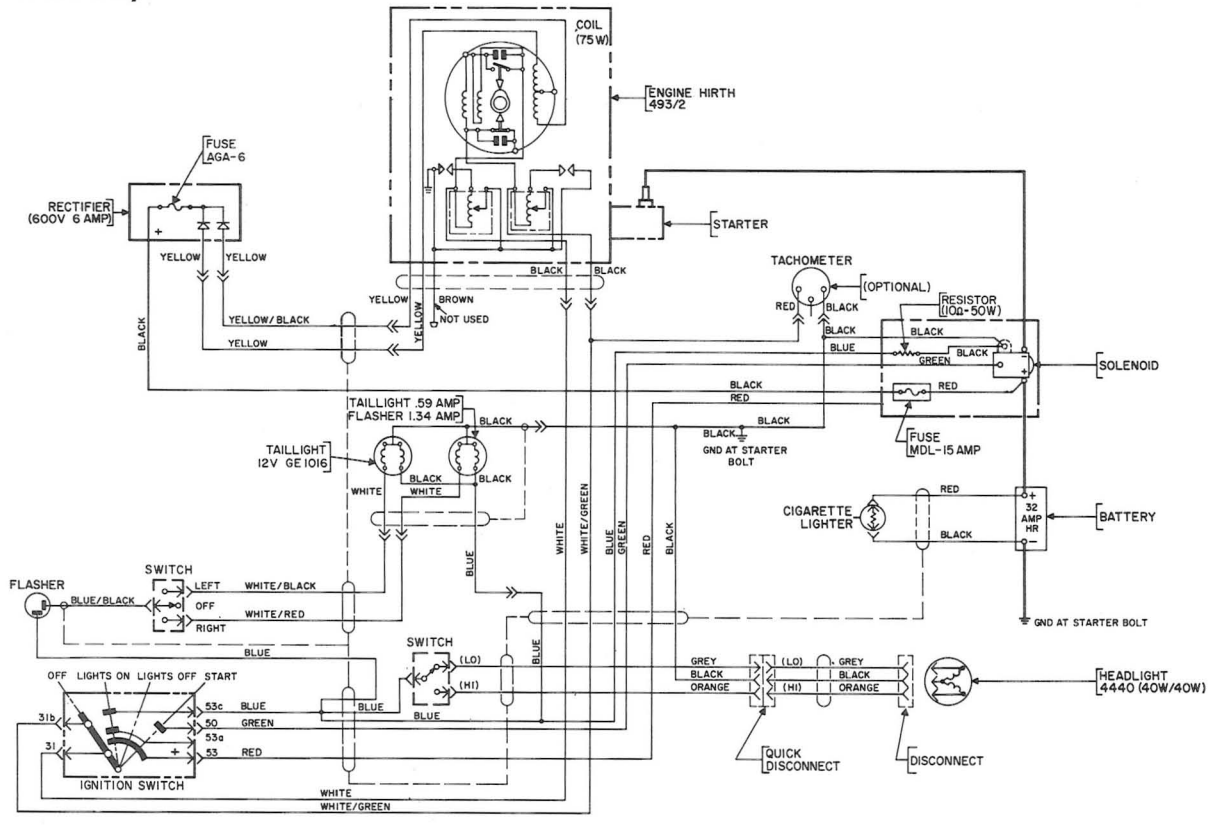

Figure 18