



Snowmobile and Vehicle Engines

**Models**

**55R · 82R**

---

**Owner's  
Maintenance and  
Operating Instructions**

ISSUE MM-321



**WISCONSIN MOTOR**

MILWAUKEE, WISCONSIN 53246

EXCLUSIVE SALES AND SERVICE REPRESENTATIVES FOR HIRTH ENGINES

# TECHNICAL DATA

## SINGLE CYLINDER TWO-STROKE ENGINE

**82R**

**55R**

ENGINE OUTPUT AT 5000 R.P.M.....	12 DIN H.P. ....	15 DIN H.P.
DIRECTION OF ROTATION .....	Counter clockwise in view of P.T.O. Shaft .....	Counter clockwise in view of P.T.O. Shaft
BORE .....	70 mm (2.76 ins.) .....	75 mm (2.95 ins.)
STROKE .....	64 mm (2.52 ins.) .....	68 mm (2.67 ins.)
PISTON DISPLACEMENT .....	246 ccm (15.0 cu. ins.) .....	300 ccm (18.30 cu. ins.)
IGNITION TIMING .....	21° or 2.6 mm before TDC (0.102 ins.) .....	To be set when engine is <b>NOT</b> running: 7° before TDC equal to 0.50 mm (0.020 ins.) Advances automatically when engine is running: 25° before TDC equal to 3.95 mm (0.156 ins.)
POINT GAP .....	0.4 ± 0.05 mm (0.016 ± 0.002 ins.) .....	0.4 ± 0.05 mm (0.016 ± 0.002 ins.)
RECOMMENDED SPARK PLUG .....	Champion UK 10 or Bosch M 225 T 1 .....	Champion UK 10 or Bosch M 225 T 1
SPARK PLUG GAP .....	0.5 + 0.1 mm (0.02 + 0.004 ins.) .....	0.5 + 0.1 mm (0.02 + 0.004 ins.)
IGNITION UNIT .....	Bosch dynamo magneto .....	Bosch dynamo magneto ignition with advance timing

**Note:** Any instructions in this manual pertaining to a decompression valve apply only to engine model **55R3**,

**MODEL  
82R**

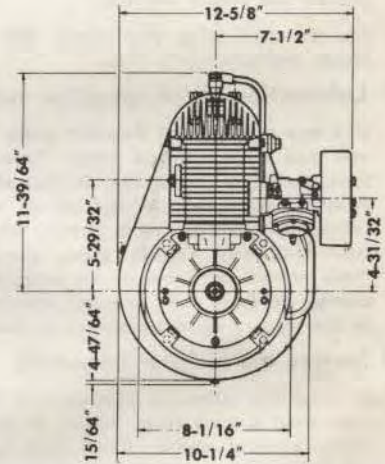
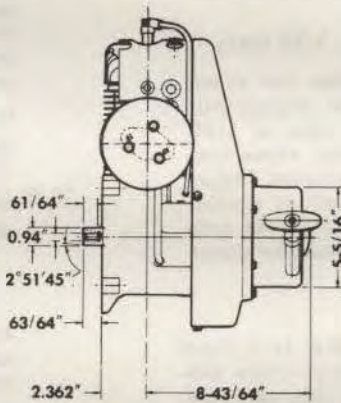
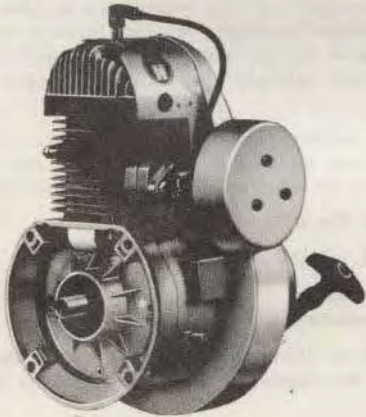

**MODEL  
55R3**

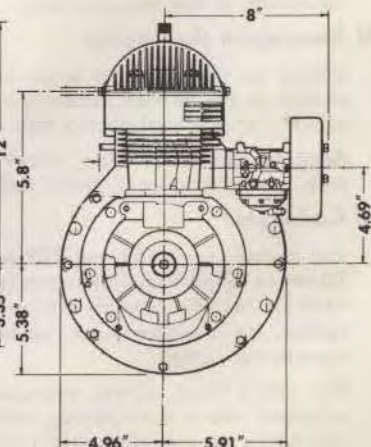
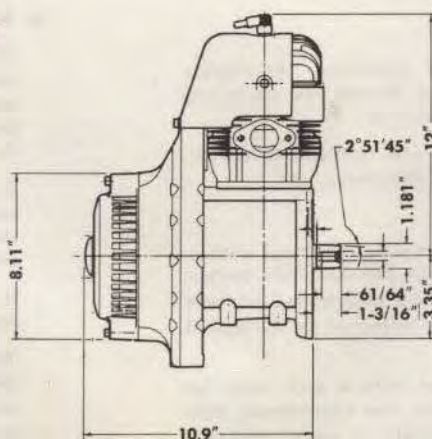
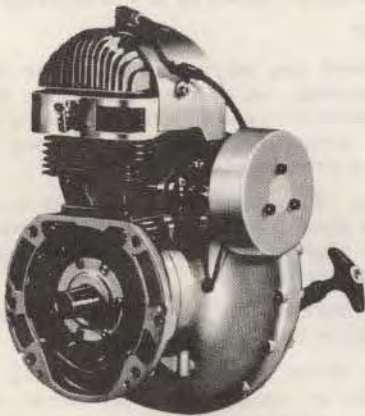

# Special execution for snow vehicles

## Single Cylinder Engine Models 55R - 82R

### Section I.

#### General instructions for engine maintenance, care and operation

##### 1) Keep all exposed surfaces and parts of the engine clean

The openings at the starter housing must be kept clean at all times, since the cooling air enters there. Also the spaces between the cooling fins of cylinder and cylinder head must be free of any foreign matter - for maximum cooling. If necessary, remove the air guide plate to clean all spaces.

Never hose the engine with water since trouble may develop in the ignition system and the carburetor.

Check exhaust port in the cylinder every 100 to 200 hours of operation to determine if it is blocked with carbon. To clean, take off muffler and exhaust manifold and remove carbon from muffler connecting pipe and flange. Clean out the exhaust silencer and the exhaust manifold. Next rotate engine so that the piston is at Top Dead Center position thus covering completely the exhaust port. Remove all carbon from port taking great care that the piston is not scratched during this operation. Dismount the cylinder head if the piston bottom is badly carboned. Remove carbon carefully from the combustion space in the cylinder head and on the piston bottom.

Check spark plug gap every 100 hours. If burnt too much, replace spark plug.

##### 2) Lubrication by oil/gasoline mixture, 1:25 ratio

Use any commercial Regular grade gasoline (not super) and mix with a brand name "two stroke engine oil" (containing a corrosion inhibitor) in a ratio of 1:25. Always mix gasoline and oil in a proper, clean container using a fine mesh screen where possible. Important: Use only Regular grade gasoline and oil marked "two stroke with corrosion inhibitor". As far as self-mixing oil from cans is used, attention should be drawn to the mixing ratio indicated on the cans.

##### 3) Service the airfilter frequently

In case the filter is supplied by HIRTH it is a layer type with a coco fibre insert. A sheet metal cover protects against snow. From time to time the cartridge should be thoroughly cleaned by dipping it into gasoline. Afterwards it should be soaked in oil (any ordinary engine oil). Allow the oil enough time to stop dripping before replacing cartridge to filter. For other filters please consider the respective maintenance instructions of the manufacturer.

##### 4) Running-in the engine

During its first 5 to 10 hours of operation, the engine should be run-in with utmost care. Do not rev up to top R.P.M., or overload during this period.

After the first few hours, check and tighten, if necessary, all screws, nuts, bolts and fasteners, etc.

##### 5) Carburetor

The engine types 55R and 82R are both equipped with a Tillotson diaphragm carburetor type HR-3A. This carburetor has an idle-mixture orifice and high-speed mixture orifice. Its cross-sections can be adjusted by a conical adjustment screw.

The idle-mixture screw, provided with a slot, may be adjusted with a screwdriver, while the high-speed mixture screw is provided with a toggle to permit adjustment by hand.

The proper adjustment of the carburetor is of utmost importance, and it requires much practice and experience. If improperly set, the engine could be damaged.

#### 1) Basic Rules:

- a) A fuel mixture that is too lean could cause the engine to overheat and the piston to wear out. However, if the mixture is too rich, the operating safety of the engine is not impeded.
- b) Opening the mixture screws (counter-clockwise) makes the mixture richer. Closing the mixture screws (clockwise) makes the mixture leaner.
- c) The idle adjustment may be said to be without or almost without effect on the performance and the temperature of the engine. But the idle adjustment is of importance for the behavior of the engine at start, in the idle run, as well as acceleration in the lowest RPM range.

The high-speed adjustment is solely responsible for the performance and temperature of the engine. It is, therefore, of utmost importance to be especially careful when adjusting the high-speed adjustment screw.

- d) It is not possible to pinpoint a specific, generally accepted position for the two mixture screws, as this position depends on the engine itself (the filter and the exhaust muffler), on the built-in position of the engine on the sled, on the outside temperature and the altitude in which the sled is operated.

It is therefore recommended that, while ascertaining that the initial mixture not be too lean, the following procedure be adopted in setting the mixture:

#### 2) Rules of setting the adjustment

##### a) Recommended initial setting:

idle-mixture screw	open 1½ turns
high-speed mixture screw	open ¾ to 1 turn

To move them to that position, the two mixture screws should be tightened (clockwise) until they stop.

Warning: the mixture screws must not be forced into their sockets.

Subsequently, the idle mixture screws should be turned counter-clockwise by 1½ turns. The high-speed mixture screw should be turned by ¾ to one turn.

##### b) Idle adjustment

The idle adjustment may be undertaken while the sled is at a standstill, as soon as the engine has warmed up: a careful loosening and tightening of the idle mixture screw will adjust the running of the engine until it fires steadily.

If the mixture is too lean, the engine will over-accelerate, then show a lack of acceleration when the gas pedal is slightly depressed, and then back-fire through the carburetor.

If the mixture is too rich, the engine will fire only after every second or third revolution.

The idle-mixture screw is in the right position if the engine picks up speed noticeably after the screw is tightened a bit more. If this does not happen, the mixture may be considered as being too lean.

Next, the idling speed will be adjusted to its proper setting, as specified by the instructions of the manufacturer, by means of turning the idle-speed screw (please note: not by means of the idle mixture screw).

### c) High-speed adjustment

The high-speed adjustment may be determined only while driving, at open throttle under full load, when the engine is at operating temperature. In order that an adequate estimation of the setting of the high-speed adjustment screw be arrived at, a distance of 1/2 to 1 mile will have to be covered. In doing so, the recommended basic setting of 3/4 to 1 turn will have to be adhered to at start.

If the adjustment turns out too rich, the engine will not achieve the maximum number of revolutions; it will release smoke and will work in a four-stroke manner rather than the foreseen two-stroke cycle. If such is the case, the high-speed mixture screw will have to be turned clockwise by at most 1/8 of a turn, later even only by 1/16 of a turn – and a new test run will have to be made.

This procedure will have to be repeated until the engine finally starts operating in the 2-stroke manner, without smoke, at a fully open throttle. Once this is achieved, it is of no consequence if the engine briefly reverts to the 4-stroke cycle if the gas pedal is released quickly.

This setting of the high-speed mixture screw, once attained, provides for greatest efficiency and prevents an overheating of the engine. Once this position is carefully arrived at, it should be adhered to without making any further changes, at least as long as the external conditions of using the engine remain the same.

### d) The effect of elevation above the sea level and of outside temperature

In higher-lying areas (starting with about 3000 feet above the sea level), as well as at exceedingly high or low outside temperatures, there is a change in the composition of the air-fuel mixture even though the adjustment of the carburetor remains the same. As a consequence, the basic rule is as follows: in higher areas and in exceedingly hot outside temperatures the high-speed mixture screw should be opened a bit less than under normal operating conditions; in very cold temperatures, the screw is to be opened a bit more. However, the proper setting for the engine may also be arrived at by following the procedures as described under 2c).

## Section 2.

### Starting and stopping the engine

In case, Model 55R is equipped with a decompression valve to facilitate the starting of it, you have to proceed for starting as follows:

Open the decompression valve by operating the lever of the cable Bowden. Start the engine as mentioned below.

Close the decompression valve as soon as the engine runs.

Attention: Do not operate the decompression valve during the engine runs and in order to stop the engine.

#### A) Starting the cold engine

- 1) Open the fuel cock.
- 2) Close choke by moving lever to "UP" position.
- 3) Set throttle at half or full open, depending on engine response.
- 4) For engines equipped with recoil starter, take the handle of the starter in your right hand and support

yourself with your left knee on the seat cushion. Pull out the handle until you feel a marked resistance. From this point, pull the handle in a vigorous and rapid manner out to about 60 cm. or 2 feet. Allow the handle to recoil slowly while still holding in your hand until it returns to the starter housing. Do not release. This slow return enables the internal spring to re-wind the cable on the starter pulley.

Pull the recoil starter vigorously a few times in order to allow the fuel pump to prime the carburetor.

- 5) The moment the engine starts, open the choke lever to "down" position.

#### B) Stopping the engine

- 1) To shut off the engine, set the throttle lever to the idling position and turn off the ignition key. In some models using the recoil starter, the engine is shut off by pushing a small short-circuit button located either on the engine or the body of the vehicle. Do not switch the engine on again until it has come to a complete stop. Switching it on again may cause back-firing resulting in serious damage to the muffler.

#### C) Starting the warm engine

- 1) Make sure that choke lever is open or in the "down" position. Open throttle about 1/4 way. Pull the recoil starter vigorously. If the engine should fail to start after 3 or 4 times, probably it has cooled down enough to require the choke. Close choke in the "UP" position about half-way and repeat with the recoil starter until engine starts.

## Section 3.

### Major starting troubles and how to remedy them

#### A) Engine fails to start due lack of fuel

**Trouble A:** Fuel cock has not been opened. Fuel tank is empty.  
Fuel line is blocked by dirt etc.

**Remedy** Open the fuel cock. Fill the tank with fuel mixture.  
Clean the fuel cock, fuel lines and carburetor including the Idling and Main orifices.

**Trouble B:** Choke lever in "down" position when engine is cold.

**Remedy** Close choke lever to "UP" position and repeat starting of engine until carburetor floods.

#### B) Engine fails to start due to excess of fuel

**Trouble A:** Choke lever closed in "UP" position too long by mistake.

**Remedy** Open choke lever, set the throttle lever to full open position and turn off the fuel cock. Pull recoil starter until the engine starts then reduce the throttle and open up the fuel cock.

**Trouble B:** Carburetor trouble or interrupted running due to fuel supply.

**Remedy** Read carefully the special instructions given in the Tillotson carburetor pamphlet.

#### C) Spark plug troubles

There are two major troubles of the spark plugs: The plug becomes too warm or too cold. At very high or very low load it might be necessary to use a plug with a higher or a lower heat value than is installed. Usually, from the appearance of the plug one can learn whether the correct plug was chosen. (See Technical Data regarding heat value.)

a) **Spark plug with correct heat value:**

Insulator light brown to grey, body has a dry, black covering. According to the fuel also, grey-white powdery sediments are normal.

b) **Spark plug with too low heat value:**

Middle and ground electrodes are swollen and show appearances of deterioration, or glasslike, yellowish coverings are on the insulator and electrodes.

c) **Spark plug with too high heat value:**

Heavy soot coating (sooted), or black, moist, shiny covering (oiled up).

d) **Further possible troubles:**

Bridge-building at the electrodes, too big gap, or flooding carburetor.

**Remedy** Clean the spark plug. Adjust the gap of the electrodes to  $0.020 + 0.004$  in. Connect the spark plug to the spark plug hood or cover, and place on the air guide plate. Turn the engine over quickly and if the plug is in good condition a spark will pass regularly between the electrodes. If the spark passes only occasionally or always on the inside of the plug or if no spark is detectable, then exchange the spark plug for a new one.

**Trouble** Ignition cable defective.

**Remedy** If there is evidence of chafing or kinking in the cable do not repair - exchange for a new one.

**Trouble** Spark plug connector or hood has no contact to ignition cable.

**Remedy** Check ignition cable as well as spark plug hood. Properly attach and/or renew spark plug hood if necessary.

When mounting the spark plug hood, proceed as follows:

Press the tip of the spiral spring through the end and center of the ignition cable. Shove the spiral spring under pressure (with oil), into the spark plug hood in such a way that the spiral will point towards the spark plug.

**Trouble** Trouble in the ignition unit. Check this by disconnecting the spark plug hood from the ignition cable and hold the metal core of the cable 4 mm or 0.15 in. away from a metal part of the engine. While turning the engine over fast, the spark must pass the above mentioned distance of 4 mm or 0.15 in.

**Remedy** Assuming that the cable is in good condition, check the contact breaker gap and clean the contact breaker points, or have the entire ignition system checked by a mechanic. In general, the nearest available Bosch Service Center should be consulted on all ignition matters.

# INSTRUCTIONS FOR ENGINE PROTECTION

Under certain duty conditions present-day fuels leave harmful residues (acids) in the engine. These residues may lead to serious corrosion and heavy damage (corroded bearings) when the engine is shut down for a considerable period. Engines with low total running times are particularly liable to this trouble.

For this reason HIRTH engines are supplied with scavenging oil after the final tests. We strongly recommend to repeat these protective measures if it is likely that the engine will remain unused for some time after it was operated. In any case the engines shall be protected anew after the operation season, that means before being laid up.

For protection of the engine the following procedure is adopted:

1. Clean the engine at the outside.
2. Remove the spark plug.
3. Set the piston at bottom dead center. To do this the piston head is contacted with a screwdriver or similar tool through the spark plug orifice and the engine is slowly turned over until the piston has reached its lowest position.
4. Introduce the funnel (part No. WS3) with the bent pipe through the spark plug orifice downwards along the cylinder wall until the end of the pipe enters clearly into the transfer port (see sketch). The two transfer ports are located at the front and rear of the cylinder; the inlet and exhaust ports are located on the right and left-hand side.
5. Introduce into each transfer port through the funnel at least 15 c. c. (1/2 oz.) of scavenging oil. If scavenging oil cannot be obtained it may be replaced by one of the usual commercial brands of anti-corrosion oil for two-stroke engines.
6. After introducing the scavenging oil turn the engine over several times by hand but do not start the engine.
7. During the storing period turn the engine over every 4 - 6 weeks so that all parts are re-wetted with scavenging oil.

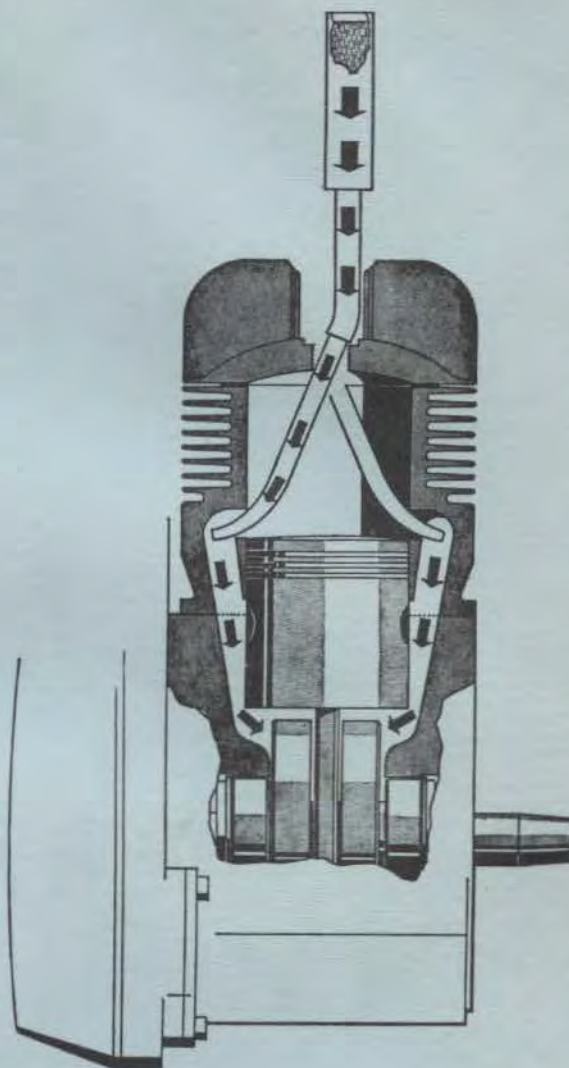

## Returning engine to service:

Clean the spark plug if wetted with scavenging oil. Close the starter throttle of the Tillotson carburetor. Start engine normally. In case the engine dies down, clean-spark plug once more and repeat starting. Let the engine run until oil is burned up.

## Suitable scavenging oils:

**BP:** BP Energol engine protecting oil

**BV-ARAL:** Aral engine protecting oil 20 W 20

**ESSO:** Rust-Ban 339

**MOBIL OIL:** Mobil Kote 503

**SHELL:** Shell Ensis Oil 20

These oils must not be mixed with gasoline but should be kept only for scavenging the engine.

For running the engine, always use a brand mark two-stroke oil with oxidation-corrosion inhibitor.