

moto-ski "F" moto-ski "S"



Congratulations. You are now the owner of a Moto-Ski. We are happy you have chosen us, and wish you a happy and exciting winter. We strongly urge you, before taking your first run, to carefully read this brochure on the general handling of your Moto-Ski, its driving, equipment and general maintenance, as well as helpful advice on safety tips and what to do in case of an emergency. Take advantage of Moto-Ski's follow-up service, which enjoys an enviable reputation. It is at your disposal. Use it, it is big, useful and has a network of competent and responsible mechanics waiting to serve you.



SPECIFICATIONS

- | | | | |
|-----------------------|---------------------|-------------------------------|----------------------|
| 1. Ski shock absorber | 10. Brake system | 18. Primer | 25. Frame |
| 2. Skis | 11. Windshield | 19. Passenger handles | 26. Slide suspension |
| 3. Front bumper | 12. Driven pulley | 20. Seat | 27. Track |
| 4. Muffler | 13. Handle bar | 21. Rear bumper | 28. Chain case |
| 5. Hood | 14. Fuel tank | 22. Cutter coupler | 29. Ski springs |
| 6. Drive pulley | 15. Tachometer | 23. Snow guard | 30. Spring couplers |
| 7. Headlights | 16. Speedometer | 24. Suspension shock absorber | |
| 8. Engine | 17. Ignition switch | | |

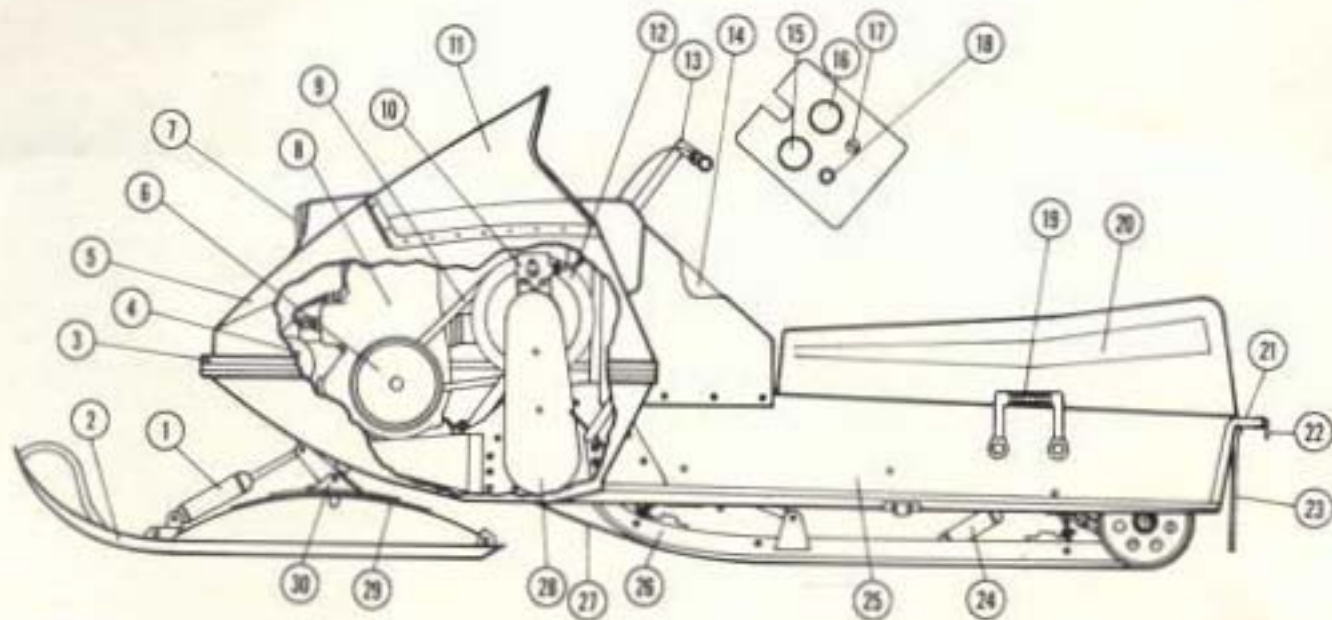

SAFETY HINT: BE AN ACTIVE MEMBER OF A SNOWMOBILE CLUB. YOU WILL LEARN A LOT FROM THE OTHER MEMBERS.

	Moto-Ski (F)		Moto-Ski (S)		
BSE Engine					
Model	295	340	440	400	440
No. of Cylinders	2	2	2	2	2
Cooling	Forced Air	Forced Air	Forced Air	Free Air	Free Air
Starter Manual	Yes	Yes	Yes	Yes	Yes
Starter Elec.	No	Opt.	Opt.	No	No
Bore	57.0 m.m.	60 m.m.	68 m.m.	64.5 m.m.	67.5 m.m.
Stroke	57.5 m.m.	60 m.m.	60 m.m.	61.0 m.m.	61.0 m.m.
Displacement	293.5	336	437	399	437
Overall Length	102"	102"	102"	102"	102"
Overall Width	35"	35"	35"	35"	35"
Overall Height	42½"	42½"	42½"	38"	38"
Height W.O. Windshield	34½"	34½"	34½"	34½"	34½"
Dry Weight	380 lbs	395 lbs	395 lbs	400 lbs	400 lbs
Ground Bearing Area	1139 sq. in.	1139 sq. in.	1139 sq. in.	1139 sq. in.	1139 sq. in.
Ground Unit Pressure	.33 lbs. per sq. in.	.35 lbs. per sq. in.	.35 lbs. per sq. in.	.35 lbs. per sq. in.	.35 lbs. per sq. in.
Brake Type	Disc	Disc	Disc	Disc	Disc
Dia. on which Lining acts	9½"	9½"	9½"	9½"	9½"
Lining Area	1.6"	1.6"	1.6"	1.6"	1.6"
Head Light	45/45	60/60	60/60	60/60	60/60
Tail Light	5 watts	5 watts	5 watts	8 watts	8 watts
Brake Light	18 watts	18 watts	18 watts	23 watts	23 watts
Lighting Coil Output	55W. at 12V.	100W. at 12V.	100W. at 12V.	75W. at 12V.	75W. at 12V.
Spark Plug (NGK)	N/A	B7HS	N/A	N/A	N/A
Spark Plug (Champion)	L4G or L3G	L78 or L3G	L78 or L3G	N2 or N59G	N2

340

	Moto-Ski (F)			Moto-Ski (S)	
Spark Plug GAP	.020"	.020"	.020"	.020"	.020"
Breaker Point GAP	.014" to .018	.014" to .018	.014" to .018	.014" to .018	.014" to .018
Fuel Tank CAP (U.S.)	6.5 gal.	6.5 gal.	6.5 gal.	6.5 gal.	6.5 gal.
Fuel Tank CAP (Imp.)	5.4 gal.	5.4 gal.	5.4 gal.	5.4 gal.	5.4 gal.
Fuel Mixture Ratio	40 to 1 (Moto-Ski Oil)	40 to 1 (Moto-Ski Oil)	40 to 1 (Moto-Ski Oil)	40 to 1 (Moto-Ski Oil)	40 to 1 (Moto-Ski Oil)
	20 to 1 (Regular 2 cycle oil)	20 to 1 (Regular 2 Cycle Oil)	20 to 1 (Regular 2 cycle Oil)	20 to 1 (Regular 2 Cycle Oil)	20 to 1 (Regular 2 Cycle Oil)
Gasoline	Premium	Regular	Regular	Premium	Premium
Track Width	17"	17"	17"	17"	17"
Material	3-ply rubberized nylon	3-ply rubberized nylon	3-ply rubberized nylon	3-ply rubberized nylon	3-ply rubberized nylon
Traction	Rubberized Steel Cleats	Rubberized Steel Cleats	Rubberized Steel Cleats	Rubberized Steel Cleats	Rubberized Steel Cleats
Drive	Twin Sprockets	Twin Sprockets	Twin Sprockets	Twin Sprockets	Twin Sprockets
Ski Suspension	(4) Leaf Springs (1) Helper Spring on each Ski — Shock Absorber Standard	(4) Leaf Springs (1) Helper Spring on each Ski — Shock Absorber Standard	(4) Leaf Springs (1) Helper Spring on each Ski — Shock Absorber Standard	(4) Leaf Springs (1) Helper Spring on each Ski — Shock Absorber Standard	(4) Leaf Springs (1) Helper Spring on each Ski — Shock Absorber Standard
Track Suspension	Slide Rail with Shock Absorber	Slide Rail with Shock Absorber	Slide Rail with Shock Absorber	Slide Rail with Shock Absorber	Slide Rail with Shock Absorber
Transmission Type	Torque Converter (Vari-Drive by belt)	Torque Converter (Vari-Drive by belt)	Torque Converter (Vari-Drive by belt)	Torque Converter (Vari-Drive by belt)	Torque Converter (Vari-Drive by belt)
Low Ratio	3.3 to 1.0	3.3 to 1.0	3.3 to 1.0	3.3 to 1.0	3.3 to 1.0
High Ratio	1.0 to 1.18	1.0 to 1.18	1.0 to 1.18	1.0 to 1.18	1.0 to 1.18
Chain Case Ratio	3.0 to 1	2.5 to 1	2.3 to 1	2.7 to 1	2.3 to 1
Top Sprocket	10 teeth	12 teeth	13 teeth	11 teeth	13 teeth
Bottom Sprocket	30 teeth	30 teeth	30 teeth	30 teeth	30 teeth
Lubrication	Low Temp. Grease (Zonium Base)	Low Temp. Grease (Zonium Base)	Low Temp. Grease (Zonium Base)	Low Temp. Grease (Zonium Base)	Low Temp. Grease (Zonium Base)

SAFETY HINT: ALWAYS WEAR A SAFETY HELMET. IT CAN SAVE YOUR LIFE AT ANY MOMENT.

CONTROLS

The Moto-Ski "F" and/or "S" controls are well located and of easy access. They have been designed for your safety. Their ruggedness and ease of operation will give you perfect control of the vehicle.

HANDLE BAR CONTROLS THROTTLE.

The throttle lever is located on the right hand side of the handle bar (fig. 1, ref. A). It controls the speed of the vehicle and also the "vari drive transmission". Press down the lever to engage the transmission and to increase the speed. Release the lever to decrease the speed. The vehicle's speed is proportional to the pressure exerted on the lever. When completely RELEASED the engine must return by itself to IDLE, and the "vari drive transmission" must come to NEUTRAL.

HANDLE BARS.

The steering handle bars are located directly behind the windshield (fig. 1, ref. B). When turned to the right, the vehicle will steer in the same direction and the opposite, when turned to the left.

BRAKE.

The brake lever is located on the left hand side of the handle bar (fig. 1, ref. D). To apply the brake, press down the lever. BRAKING IS PROPORTIONAL TO THE PRESSURE EXERTED ON THE LEVER.

"HI"-"LO" BEAM SWITCH.

The "Hi"-"Lo" beam switch is located beside the brake lever (fig. 1, ref. C). This switch permits the selection of the high or the low beam of the head lamp. To obtain either beam positions, press down the switch button.

SHUT-OFF SWITCH.

The emergency engine shut-off switch is located on the right hand side of the handle bar (fig. 1, ref. E). In case of emergency, this switch can be used to stop the engine. To stop the engine, simply press down^o the switch.

^oNOTE: After usage, the switch must be pressed again to re-establish the ignition contact.

WARNING: The driver of the vehicle must familiarize himself with the functioning of this safety device. On the first outing, operate the switch several times thereby being mentally prepared for an emergency situation requesting its use. After such a situation, the source of malfunction should be determined and corrected before restarting the engine.



SAFETY HINT: IF IT IS REQUESTED BY YOUR PROVINCE OR STATE, REGISTER OR LICENSE YOUR SNOWMOBILE.

DASH CONTROLS IGNITION SWITCH.

The four (4) positions ("OFF"- "LIGHT"- "ON"- "START") ignition switch is located on the (right hand) part of the console (fig. 2, ref. A).

"OFF" — At this position, the ignition is cut. This is the only position on which the ignition key can be inserted or removed from the switch.

"LIGHT". — On position "LIGHT", the engine ignition and the light system are "on".

"ON". — On position "ON", the engine ignition is applied.

"START". — On position "START", the engine can be started electrically (if the vehicle is so equipped).

FUEL PRIMER

Located (on the left hand part of the console) (fig. 2, ref. B) the fuel primer will help to start a cold engine. The purpose of the primer is to inject some fuel directly into the engine. To start a cold engine*, press it three (3) times, then start the engine.

*NOTE: Priming is not necessary to start a warmed-up engine. Excessive priming may result in a flooding condition.

TACHOMETER

The engine tachometer is located on the left hand side of the upper part of the console (fig 2, ref. D). The tachometer indicates the number of revolutions per minute of the engine (from 0 r.p.m. to 8000 r.p.m.).

SPEEDOMETER

The speedometer is located on the right hand side of the upper part of the console. It indicates the travelling speed of the vehicle, and registers in miles and tenth of a mile the distance travelled by your Moto-Ski snowmobile. (fig. 2, ref. E)

MANUAL STARTER:

The "automatic rewind" manual starter is located at right hand side of the console (fig. 2.a, ref. C). Pull on the starter rope handle to start the engine.

2

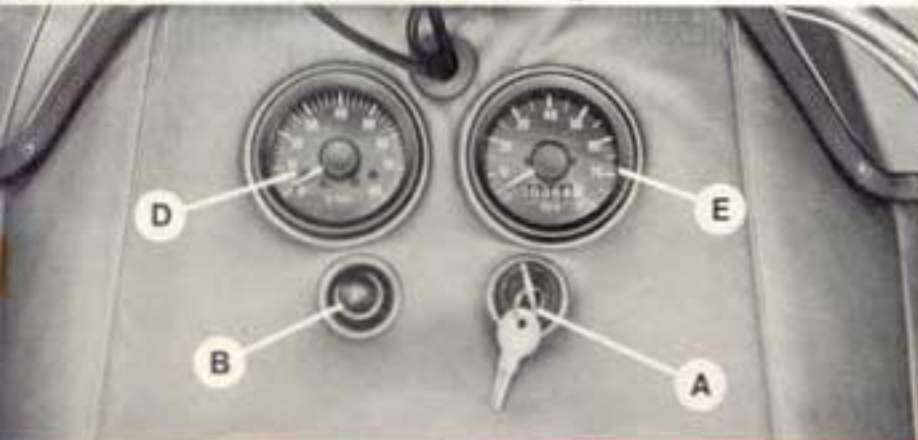

2.a



SAFETY HINT: ON A SNOW-FARI KEEP YOUR POSITION. DO NOT TRY TO IMPRESS YOUR COMPANIONS BY SOME FOOLISH STUNTS.

STARTING

PRE-START CHECK

For your safety and to obtain a longer life of your vehicle, it is of the utmost importance that you proceed, at every outing, to the "PRE-START CHECK". It will take only a few minutes of your time.

FUEL.

Check the fuel level, fill up if necessary. If you go for a long ride, see to it that you have enough fuel for the return trip. To ensure that the fuel is properly mixed, it is recommended to rock your vehicle from side to side.

THROTTLE.

To prevent any possibilities of "throttle blockage" in open position, press down[®] the throttle lever (fig. 3, ref. A) several times.

WARNING: After being pressed down, make sure that the throttle lever returns by itself to its original position.

BRAKE.

Press down[®] the brake lever (fig. 3, ref. C) several times, to make sure that there is no obstruction in the brake mechanism. The brake lever must return, by itself, to its original position.

WARNING: When pressed down to its maximum, the brake lever must not touch the handle bar. If so, a brake readjustment is required.

STEERING.

Move the steering handle bars (fig. 3, ref. B) from side to side several times, to make sure that there is no ice accumulation blocking the steering mechanism.

EMERGENCY SHUT-OFF SWITCH.

Operate the emergency shut-off switch (fig. 3, ref. E) a few times, to make sure that this important safety device is in good order.

3



SAFETY HINT: BEFORE CROSSING A LAKE OR A RIVER MAKE SURE THAT THE ICE IS THICK ENOUGH.

IGNITION SWITCH.

Insert the ignition key into the switch (fig. 4, ref. A). Turn the key to position "ON". Make sure that the emergency shut-off switch is not at "OFF" position.

WARNING: Before starting the engine, make sure that the pulley guard is in place. Never run the engine without the pulley guard.

FUEL PRIMER.

Press the fuel primer bulb* (fig. 4, ref. B) three (3) times.

*Note: To start a warmed-up engine, it is not necessary to use the fuel primer.

MANUAL STARTER.

Firmly grasp the manual starter handle (fig. 4, ref. C) and pull slowly until a slight resistance inside the mechanism is felt (this resistance indicates the starter engagement) then pull out vigorously. Guide back the rope handle to its original position. Repeat these operations until the engine starts running by itself.

NOTE: When using the manual starter, never pull out to its full extent the starter cable and do not let the starter cable fly back to the engine. In cold weather, it might be necessary to warm up the snowmobile track. To do so, tilt your vehicle on its left side (the track must not touch the ground) and gradually increase the speed until the track turns freely.

WARNING: When warming up the track, to avoid risk of accident by the turning track, make sure that no one is standing around your vehicle.

4



SAFETY HINT: ALWAYS DRIVE CAREFULLY WHEN GIVING A RIDE TO A CHILD.

FUEL MIXING

BREAK-IN PERIOD

The "break-in period" is the length of time, 10 hours* for a BSE engine, in which each internal moving part of the engine has to adapt itself with the other components in contact with it. During this period, a fuel mixture containing more oil is required (see section gasoline & oil). Moreover, the use of maximum power for a period of more than ½ minute, can be harmful to the engine.

**CAUTION: Special care must be given to the engine during the 10 hours of the "break-in period". The consumption of 2 full fuel tanks by the engine, is approximately the equivalent of 10 hours of operation.*



Like most of the 2 cycle type engines, your snowmobile's BSE requires fuel which is a mixture of gasoline and oil. The importance of using the proper mixture cannot be over-stressed, since the life of your engine depends on it. During the first 10 hours of operation a "rich" fuel mixture must be used. After the "break-in period", a mixture containing less oil is prescribed.

WARNING: To prevent any possible risks of fire when refilling your snowmobile, always stop the engine, avoid smoking, be very careful about spilling fuel over hot surfaces, such as muffler, manifold, engine, etc.



SAFETY HINT: BEFORE GOING OUT, MAKE SURE THAT YOUR CLOTHING IS ADEQUATE FOR THE OUTSIDE TEMPERATURE (REFER TO "COLD FACTOR CHART").

OIL GASOLINE &

GASOLINE.

Use only regular gasoline (not less than 80 octane) of a well-known brand. Never use "low lead content" or "no lead content" gasoline types.

OIL.

If possible, always use Moto-Ski Super Oil. This oil has been blended specially for your BSE engine. If Moto-Ski Super Oil is not available, use a well-known brand of chain saw or snowmobile oil, never use outboard or automotive type oils.

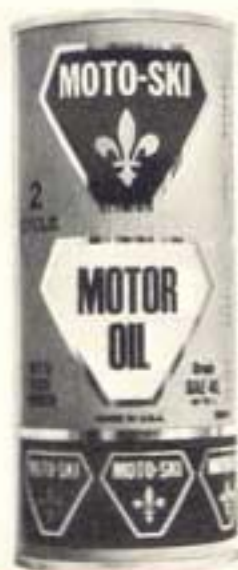

MIXING RATIO.

During the break-in period, a richer mixture is needed, 32 parts of gas for 1 part of Moto-Ski Super Oil or 16 parts of gas for 1 part of regular snowmobile oil. For normal operation (after the break-in period) a leaner mixture is needed, 40 parts of gasoline to 1 part Moto-Ski Super Oil and/or 20 to 1 with regular snowmobile oil.

MIXING CHART.

The "Fuel Mixing Chart" gives in ounces, the quantity of oil (Super Oil and Regular Oil) needed to mix 5 gallons of gasoline (imp. or U.S. gallon).

MIXING PROCEDURE.

To mix the fuel for your Moto-Ski, we strongly recommend that you prepare a large quantity of mixture each time it is needed.

**CAUTION: Never mix the oil and the gasoline directly into the fuel tank of your Moto-Ski. This can result in a wrong mixing ratio. • Into an empty container of 5 gallons, pour the required quantity of oil. • Add 2 to 3 gallons of gasoline. Shake the container well. • Add the balance of gasoline and shake thoroughly.*

FILLING PROCEDURE.

Stop the engine.

Remove the fuel tank cap.

Put on the gas tank filler neck, a funnel with a built-in fine mesh screen (the screen will prevent entry of dirt particles or water).

Fill up the gas tank. Be careful about spilling fuel over the hot muffler.

MIXING CHART

	Break-in Period		Normal Operation	
	5 U.S. Gal.	5 Imp. Gal.	5 U.S. Gal.	5 Imp. Gal.
SUPER OIL	20 on.	25 on.	16 on.	20 on.
REG. OIL	40 on.	50 on.	32 on.	40 on.

SAFETY HINT: ALWAYS STOP THE ENGINE BEFORE RE-FUELING.

OPERATION

To really enjoy riding your Moto-Ski, you must become familiar with it. You should read entirely this manual, it will help you to know your vehicle "inside-out". The manual will prepare you to face most of the unpredictable situations that may occur when snowmobiling. If another driver has to

take your snowmobile, make sure that he knows the controls perfectly. Brief him on the "pre-start" check.

WARNING: Before starting your vehicle, remember these following points: Always proceed to the "pre-start checks". • Never start the vehicle in front of an obstacle. • Do not attempt to operate the engine with the hood lifted or removed.



SAFETY HINT: ALWAYS CHECK THE WEATHER FORECAST BEFORE LEAVING FOR A LONG OUTING.

CLOTHING

Being properly clothed is the first requirement to fully enjoy snowmobiling. As you may be aware, the outside temperature decreases according to the speed of the wind. Example: A wind speed of 30 m.p.h. at 0 F. results in a relative temperature of -48 F (see "Cold Factor Chart"). Therefore a good snowmobile suit, gloves or mitts and boots are essential to truly enjoy this sport. Always wear a safety helmet, it can save your life.



COLD FACTOR CHART

		OUTSIDE TEMPERATURE (° FAHRENHEIT)											
		50°F	40°	30°	20°	10°	0°	-10°	-20°	-30°	-40°	-50°	-60°
WIND SPEED	Omph	50	40	30	20	10	0	-10	-20	-30	-40	-50	-60
	5	48	37	27	16	6	-5	-15	-26	-36	-47	-57	-68
	10	40	28	16	4	-9	-21	-33	-46	-58	-70	-83	-95
	15	36	22	9	-5	-18	-36	-45	-58	-72	-85	-99	-112
	20	32	18	4	-10	-25	-39	-53	-67	-82	-96	-110	-124
	25	30	16	0	-15	-29	-44	-59	-74	-88	-104	-118	-133
	30	28	13	-2	-18	-33	-48	-63	-79	-94	-109	-125	-140
	35	27	11	-4	-20	-35	-49	-67	-82	-98	-113	-129	-145
	40	26	10	-6	-21	-37	-53	-69	-85	-100	-116	-132	-147
		No danger (if properly clothed)				Danger (risk of frostbites on uncovered areas)				Great Danger			

SAFETY HINT: ALWAYS MAKE SURE THAT YOU HAVE THE FULL CONTROL OF YOUR SNOWMOBILE. REDUCE THE SPEED ON UNFAMILIAR TRAILS.

DRIVING RECOMMENDATIONS

If you have never driven a snowmobile, it is recommended that you practice in an open field on your first outing. Remember that driving a snowmobile is quite different from driving a car or a "bike". Each snowmobile trip changes from day to day. At every outing you have to consider the following factors:
WEATHER. (cold, warm, stormy, etc.)
TRAIL CONDITIONS. (are the trails covered by ice, powdered or hard packed snow, are they bumpy?)
AREA. (Is the area in which you intend to go flat or hilly).

URNS

Turning your snowmobile does not simply mean moving the steering handle bars to the right or to the left. The centrifugal force created when turning must be compensated by the driver himself. To turn well with a snowmobile, the driver, to compensate the centrifugal force, must shift his weight on the inside of the curve. The driver's weight shifting must be done according to the speed of the vehicle and the curve's radius.

UP-HILLS

When going up-hill the driver must shift his weight forward to produce an even pressure on the ground. Be careful about spinning the track. As soon as the track starts to spin, you must reduce the throttle in order to keep a constant traction.



SAFETY HINT: BEFORE LEAVING FOR A LONG TRIP BE SURE THAT YOU HAVE ENOUGH FUEL TO COVER THE DISTANCE THAT YOU INTEND TO TRAVEL.

HILL SIDE DRIVING

Going hill side with a snowmobile requires perfect coordination between the driver and the vehicle. To prevent side slipping, a steady speed must be maintained according to the degree of the slope. To improve the stability of the snowmobile, the driver must shift and keep his weight up-hill.

DOWNHILL

An important thing to remember when going downhill with a snowmobile is that the steering of the vehicle may become inefficient if the track is held blocked. Therefore on a downhill, never block the track by applying the brake too hard. On a steep descent never release the throttle completely (use the braking power of the engine). If needed, reduce the speed by maintaining an even pressure on the brake lever.

WARNING: If you are a novice in snowmobiling, do not over-estimate your capabilities. Using the full power of your vehicle and driving on steep slopes or hill sides are not recommended for a beginner. Remember that practice is the key to mastering your snowmobile.



SAFETY HINT: ALWAYS CARRY AN EMERGENCY KIT. DO NOT RELY ON THE KITS OF YOUR COMPANIONS TO REPLACE A DEFECTIVE PART.

SAFETY

Do not overlook this section, careful reading of the different safety hints given in this chapter may save you from an accident. The purpose of this part of the book is not to scare you but in fact to help you enjoy to its maximum the sport of snowmobiling.

THINGS TO DO

Before going out, make sure that your clothing is adequate for the outside temperature (refer to "cold factor chart").

Before starting your snowmobile always proceed to the pre-start inspection.

Before leaving for a long trip be sure that you have enough fuel to cover the distance that you intend to travel.

Always stop the engine before re-fueling.

Always make sure that you have the full control of your snowmobile, reduce the speed on unfamiliar trails. Always check the weather forecast before leaving for a long outing.

Always stop to help a distressed snowmobiler, it may happen that you will be in the same need in the future.

Always wear a safety helmet, it can save your life at any moment.



SAFETY HINT: ALWAYS STOP TO HELP A DISTRESSED SNOWMOBILER, IT MAY HAPPEN THAT YOU WILL BE IN THE SAME NEED IN THE FUTURE.

As much as possible always use well-established and known trails.

Be an active member of a snowmobile club, you will learn a lot from the other members.

Make sure that all the riding members of your family have read this book.

On a snow-fun keep your position, do not try to impress your companions by some foolish stunts.

Always carry an emergency kit. Do not rely on the kits of your companions to replace a defective part.

On a long trip always travel with at least one companion.

Before crossing a lake or a river make sure that the ice is thick enough.

Always drive carefully when giving a ride to a child.

Always stop at railroad and road crossings.

Respect people's properties and the wildlife.

If it is requested by your province or state, register or license your snowmobile.

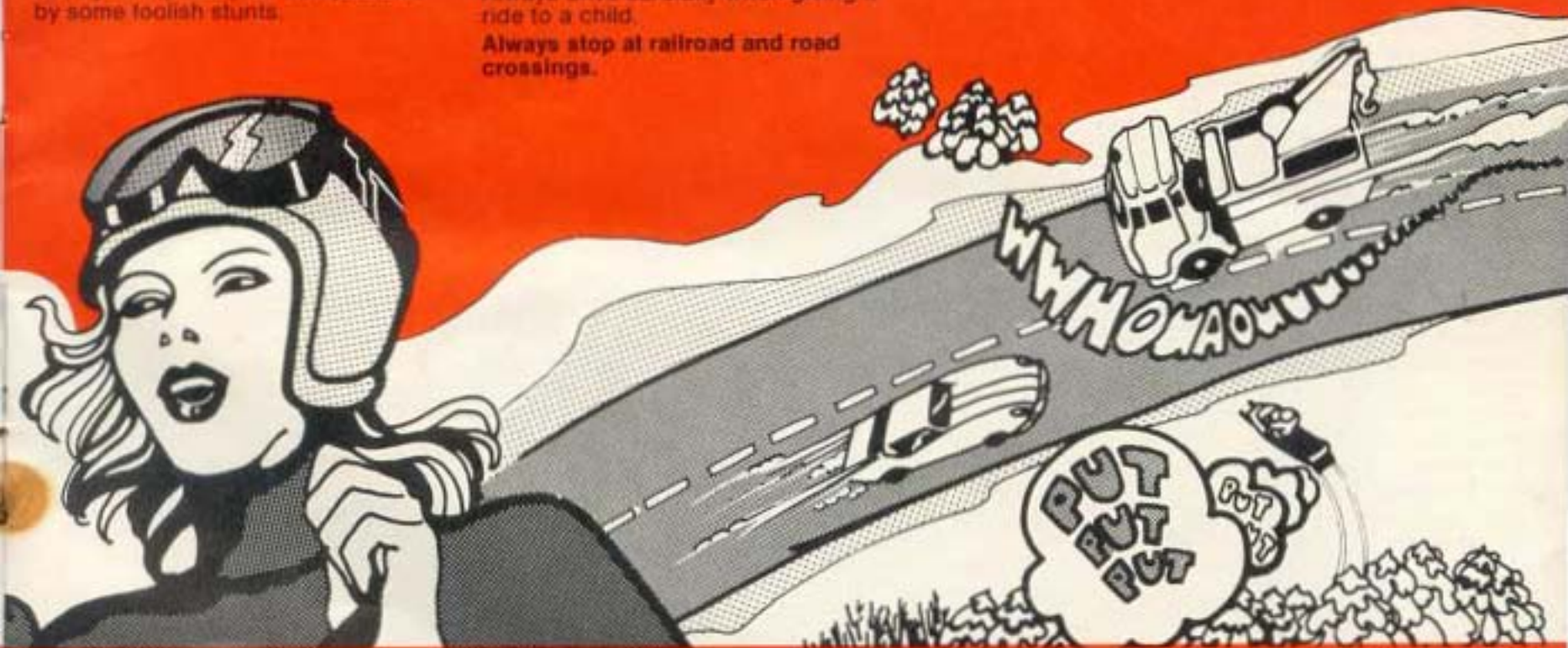

SAFETY HINT: AS MUCH AS POSSIBLE ALWAYS USE WELL-ESTABLISHED AND KNOWN TRAILS.

THINGS NOT TO DO

- Never operate your snowmobile without its pulley guard.
- Never drive with the hood lifted.
- Never ride on town streets or roads (even secondary roads).
- Never drive while under the influence of alcohol or drugs.
- Never try to perform stunts, leave that specific part of snowmobiling to professionals.
- Never ride on bare surfaces such as earth, concrete and asphalt. It is unsafe and harmful to your vehicle.
- Never travel in the area of skiers.
- Never cut the line of travel of another snowmobiler.
- If your snowmobile is left unattended, do not leave the key in the ignition switch.
- Never ride on railroad tracks while on a snowmobile — it is practically impossible to hear an oncoming train.
- When on trails do not attempt to race your companions.
- Do not overload your snowmobile, it is far better to use a sled attached to your vehicle by a rigid tow bar.
- Don't lend your snowmobile to a novice driver.

EMERGENCY KIT

To be ready to face up to most of the emergency situations that may occur when snowmobiling, you must always carry with you an emergency kit. This kit must include the following: ● The owner's manual. ● One spare drive belt (new). ● One new spark plug. ● The tool kit that was supplied with your vehicle. ● One first-aid kit. Most of the dealers keep in stock kits specially designed for snowmobilers.

- One flashlight.
- A nylon rope of 15' long ($\frac{1}{4}$ " to $\frac{3}{8}$ " diameter).
- A pair of general purpose pliers.
- For a long outing or when in an isolated area you must carry the following additional items: ● An axe in a leather case. ● An adjustable wrench (8" long). ● Spare light bulbs (head lamp and tail lamp) ● A throttle cable assembly. ● A brake cable assembly.



SAFETY HINT: ON A LONG TRIP ALWAYS TRAVEL WITH AT LEAST ONE COMPANION.

LUBRICATION

A well done and periodic lubrication will reduce wear to a minimum and will sensibly increase the life of your Moto-Ski snowmobile. Two different factors can influence the frequency of lubrication: **HOURS OF OPERATION** and **OPERATING CONDITION**. The hours of operation* can be determined by the number of full fuel tanks utilized. (1 full tank equals approx. 5 hours of operation). Tough operating conditions such as rough ground, slushy snow, etc., will double the lubricating need.

*NOTE: The average mileage in one hour of operation is about 15 miles.

LUBRICANTS NEEDED

Only two (2) types of lubricant are required to fulfil the lubricating requirements of your Moto-Ski snowmobile. (i.e. light machine oil and grease).

GREASE.

As much as possible, use the "Moto-Ski Special Grease" (low temperature grease with a ZONIUM base). If unavailable use a well-known brand of "water resistant low temp. grease".

25 HOURS LUBRICATION

After every 25 hours of operation, or more often if the snowmobile has been under adverse conditions, you should lubricate the following:

DRIVE CHAIN

Lift the hood.

Unscrew and remove the chain cover retaining nuts (fig. 7.1, ref. A).

Make sure that the drive chain is sufficiently covered with Moto-Ski Special Grease.

*NOTE: Every 25 hours, 4 to 5 shots of grease should be injected to the fitting located at the center of the case cover (fig. 7.1, ref. B).

DRIVEN PULLEY ECCENTRIC

To lubricate the driven pulley (front pulley) eccentric, proceed as follows: Remove the eccentric locking bolt (fig. 7.1, ref. C).

Through the bolt hole pump 2 to 3 shots of Moto-Ski Grease.

Tighten to eccentric locking bolt (fig. 7.1, ref. C).

*NOTE: After lubrication of eccentric, it is advisable to check the drive chain free play.



FRONT AXLE BEARINGS

Tilt the vehicle on the side and block it in this position.

At the front axle bearing (fig. 7.2, ref. A), pump the grease until new grease comes out.

With a rag wipe off the excess grease. Repeat the same operations for the bearing located on the other side of the shaft.

STEERING MECHANISM

Lift the hood.

Apply a few drops of oil on the four (4) tie rod end ball joints (fig. 7.3, ref. A) at each end of the steering linkages.

Slightly lubricate the nylon bushings of the steering column with oil.

50 HOURS LUBRICATION

After every 50 hours of operation proceed to the 25 hours lubrication. In addition lubricate the following:

BOGIE WHEELS & REAR AXLE

At each bogie wheel and at the rear axle, lubricate until fresh grease comes out.

With a rag wipe off the excess grease.

SKI LEGS

Lift the hood.

At both ski legs (fig. 7.4, ref. A) pump the hand gun until new grease appears.

Wipe off the excess grease.

SKI LEG SPRING COUPLER BOLT

Apply a few drops of oil on the bolt retaining the spring coupler to the ski leg. Repeat the same operation for the other ski leg spring coupler bolt.

7.2



7.3

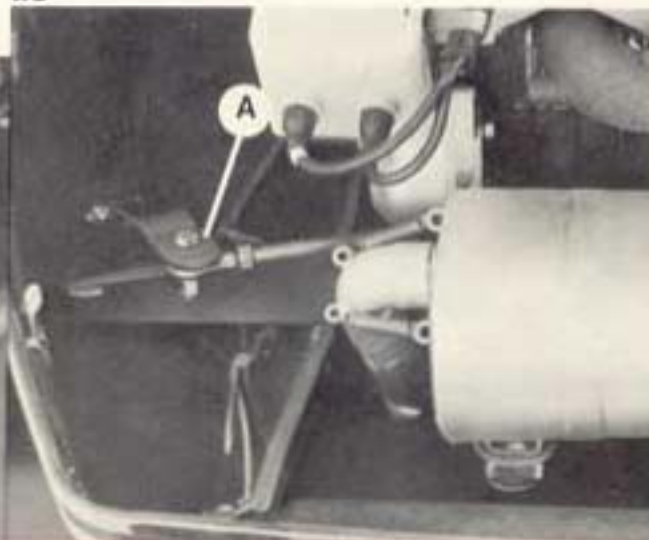

7.4



SAFETY HINT: BEFORE STARTING YOUR SNOWMOBILE ALWAYS PROCEED TO THE PRE-START INSPECTION

DRIVE PULLEY

Lift the hood and remove the pulley guard.

Unscrew and remove the centrifugal governor bolt.

Pull out the pulley sliding half.

Apply a few drops of oil on the pulley fixed half shaft.

Reinstall the sliding half and slide it back and forth in order to spread the oil within the shaft and the sliding half.

Reassemble the governor assembly.

MAINTENANCE

Safety, vehicle long life, and trouble-free performance directly depend on how well you maintain your Moto-Ski snowmobile. Poor performance is usually related to poor maintenance. Just 10 to 20 minutes a week* will be enough to keep your vehicle in top shape.

*NOTE: If you do not want to look after the maintenance of your snowmobile yourself, we strongly recommend that you see your dealer. He will take care of your vehicle and will give you fast service.



SAFETY HINT: RESPECT PEOPLE'S PROPERTIES AND THE WILDLIFE.

ENGINE

SPARK PLUG: Check the condition of the spark plug every week.

Lift the hood and tilt back the engine console.

Disconnect the spark plug cable at the spark plug.

With the socket included in the tool kit, unscrew and remove the spark plug (fig. 8.1).

Visually check the condition of the spark plug.

A brownish color (fig. 8.2, ref. A) normally indicates a well running engine, correct plug heat range and good carburation.

A black colored spark plug (fig. 8.2, ref. B) indicates a poor performing engine usually due to worn-out electrodes, too much idling, too cold heat range or a poor carburation. For the last 2 items see your dealer.

A light gray colored spark plug (fig. 8.2, ref. C) indicates a danger for your engine (faulty timing, too hot plug, etc...). See your dealer at once.

CARBURETOR

NOTE: Once your dealer has adjusted the carburetor, there is usually no need to readjust it for the rest of the season. The carburetor is one of the most delicate components of your snowmobile. If you feel that the carburetor is not functioning properly, always contact your dealer. If it becomes necessary for you to readjust it yourself, proceed as follows:

1. Maximum Throttle Opening. The carburetor throttle must be completely opened when the throttle lever is fully depressed. If an adjustment is needed, loosen the throttle cable holding screw (fig. 8.4, ref. A) and shorten or lengthen the throttle cable.



8.1

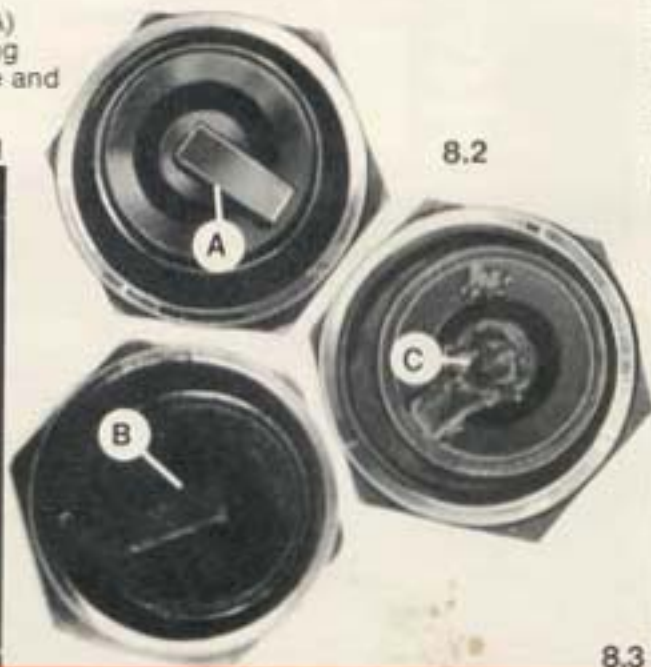

8.2

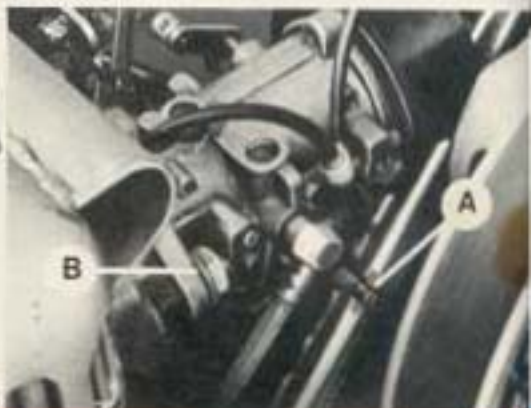

8.3

SAFETY HINT: NEVER OPERATE YOUR SNOWMOBILE WITHOUT ITS PULLEY GUARD.

*****WARNING:** After the adjustment is completed, make sure that when the throttle lever is released, the carburetor throttle is fully closed.

2. Idle Speed Mixture Adjustment.

Turn in the idle mixture screw clockwise (fig. 8.4, ref. B) until it is completely closed. (DO NOT TIGHTEN).

Turn off the adjusting screw counter-clockwise one full turn.

CAUTION: When adjusting the carburetor mixture screws, never tighten them. You can damage the screw needle and/or the seat.

3. High Speed Mixture Adjustment.

Turn the high speed mixture screw clockwise (fig. 8.3, ref. A) until it is fully closed. (DO NOT TIGHTEN).

Turn off the mixture screw counter-clockwise about 1 1/4 turns.

*****WARNING:** Do not attempt to adjust the carburetor (maximum throttle opening, idle speed mixture, and high speed mixture adjustments) with the vehicle moving or the engine running.

4. Idle Speed Adjustment. Start the engine and let it warm up.

Adjust the idle speed (between 1,800 to 2,000 r.p.m.) by turning the idle speed adjustment screw (fig. 8.4, ref. C). (Clockwise to increase and counter-clockwise to decrease the speed).

CAUTION: The idle speed r.p.m. must be set below the engine clutch engagement.

5. Carburetor Flange Nuts. After the first 15 hours of operation, the carburetor flange nuts (fig. 8.3, ref. B) must be retightened.

6. Cylinder Head. Periodically retighten to specific torque the cylinder head nuts. (See your dealer).

7. Exhaust Pipe. Periodically check the tightness of the exhaust pipe (or flange) nuts.

8. Engine mount: Periodically retighten the engine mounts.

Note: On "S" model equipped with twin carburetors, it is recommended that setting and synchronizing be done by your Moto-Ski dealer.

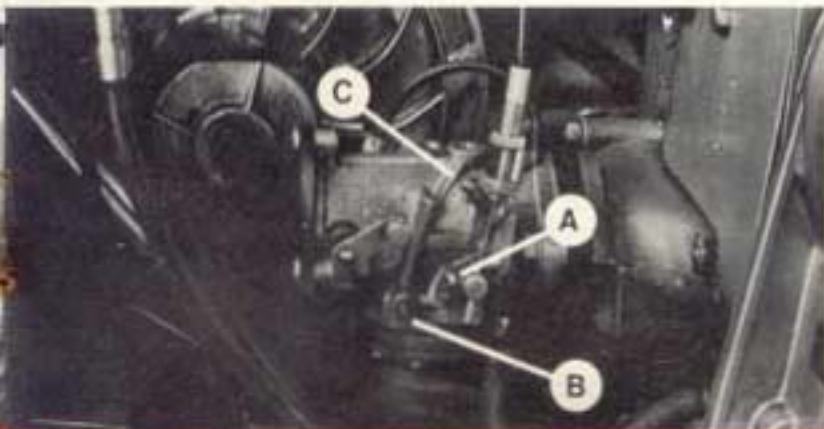

8.4

STEERING MECHANISM

To insure proper vehicle handling and stability, the STEERING MECHANISM must be kept perfectly adjusted.

HANDLE BAR & TOE IN ADJUSTMENT

With the handle bar perfectly horizontal and the skis parallel with the sides of the vehicle, the distance at the front of the skis must be $\frac{1}{8}$ " less than at the rear (Toe-In).

If an adjustment to the handle bar or to the "Toe-In" is necessary, proceed as follows:

1. lift the hood.
2. remove the nylock nuts and bolts (fig. 8.5 Ref. B) retaining tie rod ends to steering arm.

3. loosen the two (2) tie rod end lock nuts (fig. 8.5 Ref. A).

4. correct the handle bar and/or the "Toe-In" by turning one (1) and/or two (2) tie rod ends (fig. 8.5 Ref. C) clockwise or counter-clockwise.

5. re-install the nylock nuts and bolts (fig. 8.5 Ref. B).

6. tighten the two (2) locknuts (fig. 8.5 Ref. A) and recheck the adjustments.

DRIVE CHAIN

The drive chain tension must be checked regularly. The performance of your vehicle is closely related to the chain tension.

CHAIN TENSION CHECK

Lift the rear of the vehicle and support it in this position.

1. Remove the chain case cover.
2. Move back and forth the loose side of the drive chain and measure the slackness of the chain to determine the free play. (The free play must be between $\frac{1}{8}$ " to $\frac{1}{4}$ " — see fig. 8.6).
3. Turn the driven pulley one full turn and check the free play again.

IMPORTANT: To have a true drive chain tension check, you must rotate the driven pulley 3 turns and check the tension at each turn.

8.5

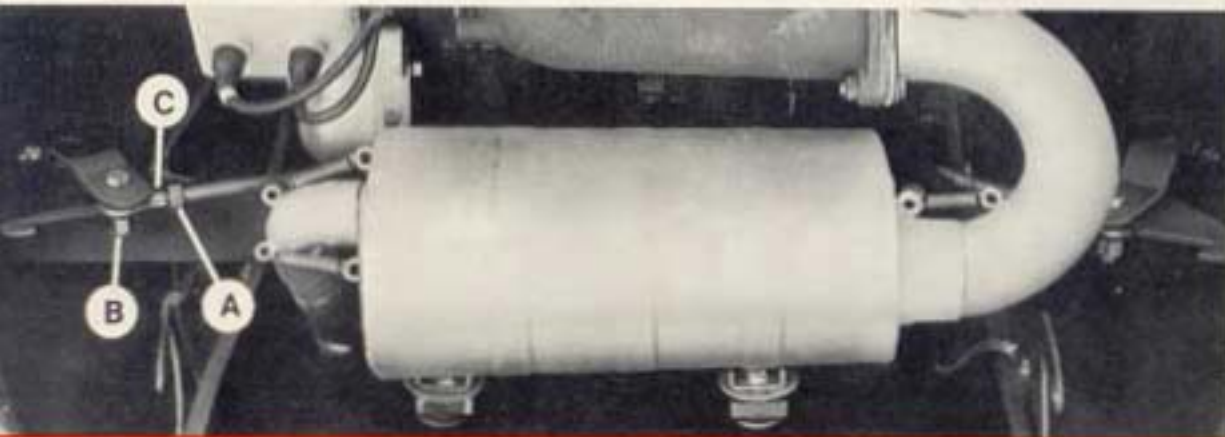

8.6



SAFETY HINT: NEVER TRY TO PERFORM STUNTS. LEAVE THAT SPECIFIC PART OF SNOWMOBILING TO PROFESSIONALS.

CHAIN TENSION ADJUSTMENT

To adjust the chain tension proceed as follows:

1. Loosen the eccentric locking bolt (fig. 8.7, ref. A).
2. Adjust the chain tension by pushing the locking bolt downward to tighten or upward to loosen.
3. Re-check the chain tension.
4. Retighten the locking bolt of the eccentric adjuster.
5. Reinstall and tighten the chain case cover.

DRIVE BELT

The drive belt condition should be checked regularly. With the ENGINE STOPPED, slowly rotate the driven pulley and check the condition of the belt. Look for cracks, fraying or uneven wear.

8.7



CAUTION: In most cases, abnormal wear is caused by a misalignment of the pulleys. Contact your dealer. Check the width of the drive belt, if less than 1" replace it.

DRIVE BELT REMOVAL

1. Lift the hood and remove the pulley guard.
2. By taking reference on fig. 8.8, to remove and replace the drive belt, proceed as follows:
 - "open" the driven pulley by pulling strongly on the upper part of the belt (near driven or front pulley).
 - while keeping the driven pulley blocked in open position, pass the belt over the drive pulley (engine clutch).

- remove the belt from the pulleys.
- place the new belt on the driven pulley. Open the driven pulley by pulling the drive belt toward the drive pulley.
- with the driven pulley opened, pass the other end of the belt over the drive pulley.

8.8



BRAKE.

There must be a clearance of 1/16" between the brake lining and the brake drum (fig. 8.10). If an adjustment is required, proceed as follows:

1. Loosen the lock nuts (fig. 8.10, ref. A) at the end of the brake cable housing (cable housing support bracket).
2. Adjust the free play with the first nut then tighten the second lock nut to secure.

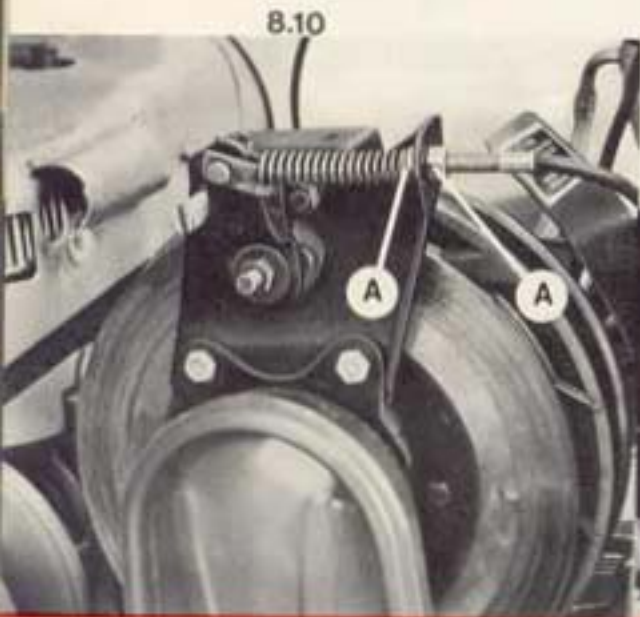

TRACK.

The track is one of the most important and valuable components of your snowmobile. A badly adjusted track will cause a noticeable lack of performance and premature wear. Two adjustments on the track have to be checked periodically.

TRACK TENSION. There should be a clearance of 1" between the bottom of the slider shoes and the center cleat of the track. If an adjustment is needed:

1. On each side of the vehicle loosen the 2 jam nuts (fig. 8.11, ref. A) retaining the adjuster screw (fig. 8.11, ref. B).

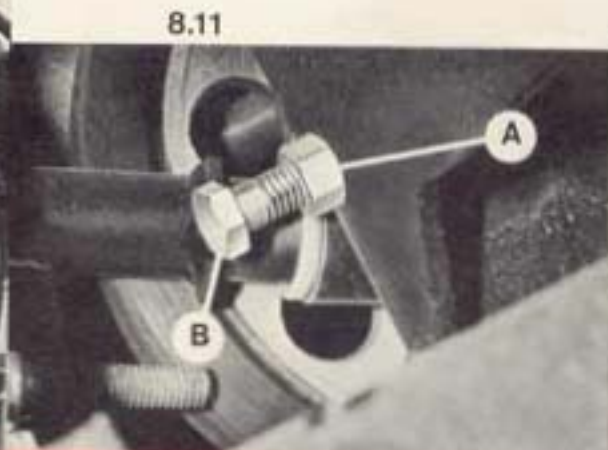

2. Turn the adjusting screws (fig. 8.11, ref. B) clockwise to tighten or counter-clockwise to loosen the track tension.

TRACK ALIGNMENT

1. Lift and block the rear of the vehicle.
2. Start the engine and slowly increase the speed until the track turns slowly.
3. With the track revolving, the two (2) slider shoes (fig. 8.12, ref. A) must be perfectly aligned into the track slots.
4. To correct the alignment turn one of the two track adjusting screws (fig. 8.11, ref. B).



SAFETY HINT: NEVER DRIVE WHILE UNDER THE INFLUENCE OF ALCOHOL OR DRUGS

SPRING OR SUSPENSION TENSION

Depending on the driver's weight and/or snow conditions, the track suspension springs can be adjusted by turning clockwise or counter-clockwise the spring turn buckle nuts of the front & rear adjusters (fig. 8.13, ref. A)

8.13



SAFETY HINT: NEVER RIDE ON BARE SURFACES SUCH AS EARTH, CONCRETE AND ASPHALT. IT IS UNSAFE AND HARMFUL TO YOUR VEHICLE.

Since your Moto-Ski snowmobile will not be used during the Summer period, it has to be prepared for these months of inactivity. A good preparation of your vehicle for the off-season will prevent rust formation and ease its preparation for the next winter.

TRACK

- Lift the rear of the vehicle and support it off the ground.
- Wash the track thoroughly with clean water. (Do not use solvent or gasoline).
- Inspect the track for any damage, missing rivets or cleats. Replace if necessary.
- Make sure that track alignment and tension are within the specifications.

SUSPENSION

- Check each bogie wheel set for possible damage.
- Replace if necessary.
- Spin each bogie wheel to make sure that the bearings are

operating properly. If necessary replace defective ones.

FUEL SYSTEM

As shown in fig. 9.1 turn by $\frac{1}{4}$ of a turn the two (2) locking rings of the console (fig. 9.1, ref. A), tilt it back and hold it in this position.

- Disconnect the fuel lines to the carburetor.
- Remove fuel tank and empty it.
- Rinse tank with a quart of pure gasoline.
- Reinstall fuel tank.
- To dry out the carburetor, start the engine and let it run until it stops by itself.
- Reconnect the fuel lines to the carburetor.

ENGINE

- Remove the spark plug (s).
- Pour 2 tablespoons of oil into each cylinder (fig. 9.2).
- Crank the engine manually about a dozen times to ensure adequate protection of cylinder wall.

9.1

CHAIN CASE

Remove the chain case cover. With a rag wipe off the grease inside the chain case and the cover, the gears and the chain.

Wash the chain case assembly (cover, gears, chain, etc.) with gasoline and dry it with compressed air or a clean cloth.

Check the condition of the chain case components (i.e. chain, sprocket, seals, etc.) and replace defective ones. Check and adjust the chain tension if necessary. Coat the chain and sprockets with Moto-Ski Special grease. Make sure that at least 10 ounces of grease is applied to the assembly.

Replace the chain case cover.

9.2

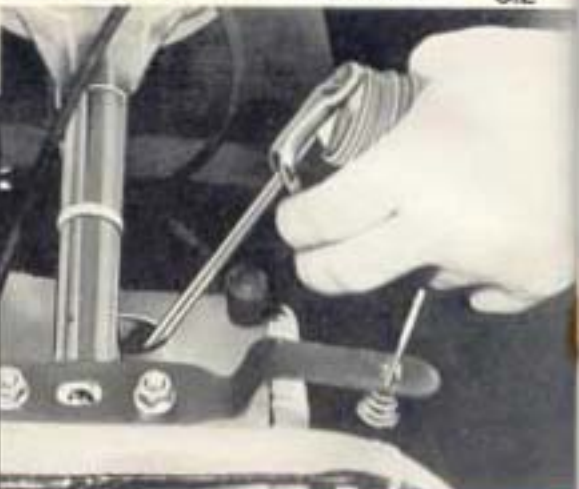

SAFETY HINT: NEVER RIDE ON RAILROAD TRACKS WHILE ON A SNOWMOBILE — IT IS PRACTICALLY IMPOSSIBLE TO HEAR AN ONCOMING TRAIN.

PRE-SEASON PREPARATION

PULLEYS

Remove the drive belt.
Spray the pulley surfaces with anti-rust compound.

NOTE — Do not reinstall the belt until the next season.

MISCELLANEOUS

Proceed to a complete lubrication of the vehicle.

Wash the inside and outside of the machine thoroughly.

Tighten any loose nuts or bolts.

NOTE — We strongly recommend that you see your dealer before storing your snowmobile. He may want to give you some further advice after inspection of your Moto-Ski.

At the end of the Summer season your Moto-Ski has to be prepared for the coming winter. To fully enjoy the coming season proceed to the pre-season preparation.

NOTE — If you complete this preparation yourself, it is strongly recommended that you bring your vehicle to your dealer for a final check and approval.

GENERAL

Check the fuel lines. Make sure that the fittings, clips etc. are well secured.

Lubricate the vehicle. Check all moving parts.

Reinstall the drive belt.

ENGINE PREPARATION

Remove the spark plug(s).

Hold a cloth over the spark plug hole(s).

To force out the oil added at the time of storage from the cylinders, crank the engine several times.

To remove the oil on the electrodes of the spark plug(s), wash the plug(s) with gasoline. Allow 5 minutes to dry.

Replace spark plug(s).

FINAL ADJUSTMENTS

Fill up the gas tank with fresh fuel.

Check and adjust the tension and alignment of track if necessary.

Check and adjust the chain tension if necessary.

Start the engine.

NOTE — If performance is still poor after one hour of operation, see your dealer.



TRUBLE SHOOTING GUIDE

SYMPTOMS	POSSIBLE CAUSES	WHAT TO DO (REMEDY)
ENGINE TURNS OVER BUT FAILS TO START OR STARTS WITH DIFFICULTY.	1 No fuel to the engine.	Check the tank level and fill up with correct gas-oil mixture. Check for possible clogging of fuel line, item 5.
	2 Faulty ignition.	Disconnect spark plug wire(s) from plug. Then hold wire about 1/8" from the cylinder head. Follow engine starting procedure and if no sparks appear, it means a faulty ignition system. Do not attempt to repair. Contact your dealer. If sparks do appear, check item 3.
	3 Spark plug(s).	Check for fouled or defective spark plug(s). First complete item 2, above. Then disconnect spark plug wire, unscrew plug and remove from cylinder head. Reconnect wire and ground exposed plug to engine head, being careful to hold away from spark plug hole. Follow engine starting procedure and check for spark. If no sparks appear, replace spark plug.
	4 Flooded engine.	Make sure that the choke is in the open position. Wait 60 seconds or more, then depress throttle lever fully and start the engine.
	5 Clogged fuel line (water or dirt).	Remove and clean the fuel filter. Change filter cartridge if necessary. Check the fuel tank and clean tank if necessary.
	6 Idle speed adjustment	Screw in the idle speed mixture adjusting screw and turn it back 1/4 of a turn. Make final adjustment with engine running and warmed up.
	7 Faulty carburetor.	First make primary adjustments on carburetor. If carburetor still faulty, contact your dealer for repair.
	8 Too much oil in fuel.	Empty the fuel tank and refill with the correct gas-oil mixture.
	9 Breaker points.	Breaker points may be worn or out of adjustment. Contact your dealer.
	10 Poor engine compression.	Running with a lean fuel mixture may produce excessive engine wear resulting in poor engine compression. If this occurs, contact your dealer at once.

ENGINE WILL NOT TURN MANUALLY.	1 Seized engine.	In the case of a seized engine, contact your dealer. Seizure is a direct result of poor lubrication.
ENGINE LACKS ACCELERATION OR POWER.	1 Fouled or defective spark plug(s)	Change your spark plug(s). Fouled spark plug(s) may be cleaned, regapped and tested by your dealer. Check for defective spark plug(s) and change if necessary.
	2 Clogged fuel line (water or dirt).	Remove and clean fuel filter. Change filter cartridge, if necessary. Check fuel line condition and connections. Check fuel tank. Clean if necessary.
	3 Carburetor.	Readjust the carburetor. If the trouble persists, contact your dealer.
	4 Defective ignition.	First check items 2 and 3 of "Engine turns over but fails to start or starts with difficulty". If the ignition system still seems defective, contact your dealer.
	5 Engine.	If unable to locate specific symptoms, contact your dealer.
ENGINE CONTINUALLY BACKFIRES	1 Faulty spark plug(s).	Check item 1 of "Engine lacks acceleration or power".
	2 Overheated.	Carburetor idle and/or High Speed mixture screws set too lean. Readjust.
	3 Engine timing incorrectly set.	Contact your dealer.
SNOWMOBILE CANNOT REACH FULL SPEED.	1 Drive belt.	Check for defective or worn drive belt. Replace if necessary.
	2 Pulley misaligned.	If the drive or driven pulleys are not aligned correctly, contact your dealer.
	3 Incorrect track adjustment.	Check track freeplay and alignment. Readjust to specifications.
	4 Faulty engine.	Check items 1 to 5 of "Engine lacks acceleration or power".

WARRANTY POLICY HIGHLIGHTS

WARRANTY TRACK

1 YEAR on twin Cylinder Models
2 Years on Single Cylinder Models
For Material Separation Only
All other defects carry a 90-day warranty

90-DAY WARRANTY

1. Body
2. Hood
3. Engine
4. Drive Shaft Ass'y
5. Rear Shaft Ass'y
6. Track
7. Bogie Pulley
8. Driven Pulley
9. Drive Pulley
10. Chain & Sprockets
11. Exhaust System
12. Handle Bars
13. Controls
14. Fuel System
15. Battery
16. Electrical System

EXCLUSIONS

1. Bulbs
2. Drive Belt
3. Leaf Springs
4. Bogie Springs
5. Rear Springs
6. Ski Runners
7. Nylon Shoes
8. Cables
9. Brake Shoes
10. Cleats
11. Filters
12. Slide Suspension
13. Points
14. Condenser
15. Spark Plugs



SAFETY HINT: DO NOT OVERLOAD YOUR SNOWMOBILE. IT IS FAR BETTER TO USE A SLED ATTACHED TO YOUR VEHICLE BY A RIGID TOW BAR.

CONSUMERS RESPONSIBILITY

It is the consumer's responsibility to ensure normal periodic maintenance and correct detailed off-season storage as prescribed in owners' manual.

WARRANTY LIMITATIONS

Where Premature Failure is caused by improper operation, misuse, neglect, accident, or if the Moto-Ski is used in races, rallies or any other form of competition including the operation of the unit on any surface other than ice or snow, the warranty does not apply. Moto-Ski Ltd. reserves the right to incorporate any changes in design of its products without obligation to make such changes on units previously manufactured.

WARRANTY SUMMARY

Every new Moto-Ski Snowmobile sold through an authorized Moto-Ski Dealer or Distributor is warranted by the Manufacturer to be free of Defective Parts or material and workmanship under normal use and service.

For complete warranty policy, please consult the section entitled "Warranty" in your owner's manual.

TRANSPORTATION

Transportation of the unit or the cost of shipment of the Snowmobile or any Parts to or from any destination for any purpose, whether connected or not with the performance of warranty, or expenses, or losses arising from the fact that the unit may not be usable or functional during any period of time by reason of defect is not covered by warranty.

1973 WARRANTY

1— Every new and unused "Moto-Ski" snowmobile sold through an authorized Moto-Ski dealer or distributor is warranted by Moto-Ski Limited (herein after called the manufacturer) for a period of ninety (90) days from the date of its delivery to the original retail customer/purchaser, to be free of defective parts or material and workmanship under normal use and service.

2— Should the date of the original purchase by a retail customer be within or less than the period of ninety (90) days immediately preceding the 1st day of May, the warranty period shall then be for a period of ninety (90) days beginning on the date of retail purchase until the 1st day of May, and the balance of the warranty period shall be carried over into the following winter season beginning with the date of the first snowfall but no later than the first day of December.

3— Should the date of the retail purchase by a retail customer be on or after the 1st day of May, the warranty period of ninety (90) days will begin with the first snowfall of the following winter season, but no later than the 1st day of December.

4— Such warranty will be honoured by any authorized Moto-Ski dealer/distributor in Canada and United States.

5— In addition to the conditions stipulated in the paragraph 1, the track is warranted against SEPARATION for a period of two (2) years from the date of delivery to the original purchaser on snowmobiles equipped with one (1) cylinder engine and similarly for a period of one (1) year on snowmobiles equipped with two (2) cylinders engine.

6— The obligation under warranty is limited to making the replacement or repair, whichever the warrantor may elect, of any parts acknowledged by the warrantor to be defective, the labour involved in repairing or replacing the defective part to be free of charge to the owner of the "Moto-Ski" snowmobile.

7— The performance of any warranty service under normal conditions will not constitute an extension to the limit of the original warranty as set forth in the paragraphs 1 and 5.

8— This warranty does not include or cover: a) the reimbursement of expenses incurred by reason of normal use, wear, exposure, off season storage reconditioning, or expenses incurred in connection with any verification or normal maintenance services (including but not limited to motor tune up, drive belt or track adjustment, timing, ski adjustment), the replacement of service items (including but not limited to spark plug, filter, drive belt, brake shoes, suspension springs, slide suspension and slider shoe, nylon shoes on driven pulley cam); b) deterioration and tear of upholstery, soft trims, and appearance items, damage or defects due to misuse, alteration, negligence or accident, damage or defects due to the repair of the snowmobile by someone other than an authorized "Moto-Ski" distributor or dealer; c) transportation of the unit or the cost of shipment of the snowmobile or any parts to or from any destination for any purpose, whether or not connected with the performance of the warranty, or expenses, or losses arising from the fact that the unit may not be usable or functioning during any period of time by reason of defect; d) if the snowmobile has been modified or is used for races, rallies, or any other competition; e) if the snowmobile is used on any surfaces other than snow or ice.

9— This warranty does not apply to any defect which results from:

- misuse or accident;
- installation of repair parts other than genuine Moto-Ski replacement parts or;
- repairs by any person other than an authorized Moto-Ski snowmobile dealer/distributor;
- lack of preventative maintenance;
- alterations or modifications other than those approved in writing by Moto-Ski.

10— Proof of ownership and warranty registration must be submitted to the service dealer by means of the Moto-Ski Service Card.

11— The responsibility of the manufacturer is limited to the conditions of this warranty and will not cover or extend in any way to the cost or expenses resulting from accidents involving the snowmobile, or any other things or persons.

12— This warranty is expressly in lieu of all other expressed or implied warranties of Moto-Ski, its distributors and the selling dealer, including any implied warranty of merchantability or fitness for any particular purpose. Neither Moto-Ski, its distributors nor the selling dealer shall be responsible, under any circumstances, for any loss or damage as a result of hidden defects, accidents, misuses or other faults.

Neither the distributor, the selling dealer nor any other person has been authorized to make any affirmation, representation or warranty other than those contained in this warranty and if made, such affirmation, representation or warranty shall not be enforceable against Moto-Ski or any other person.

moto-ski 

© T.M. Moto-Ski Limited 1972, La Pocatière, Québec, Canada
Moto-Ski Limited, whose policy is one of continuous improvement, reserves the right to discontinue or change specifications, models, equipment or prices at any time without incurring obligation.

402.075

Litho'd in Canada