

operator's manual
manuel du conducteur

NORDIK

50/60

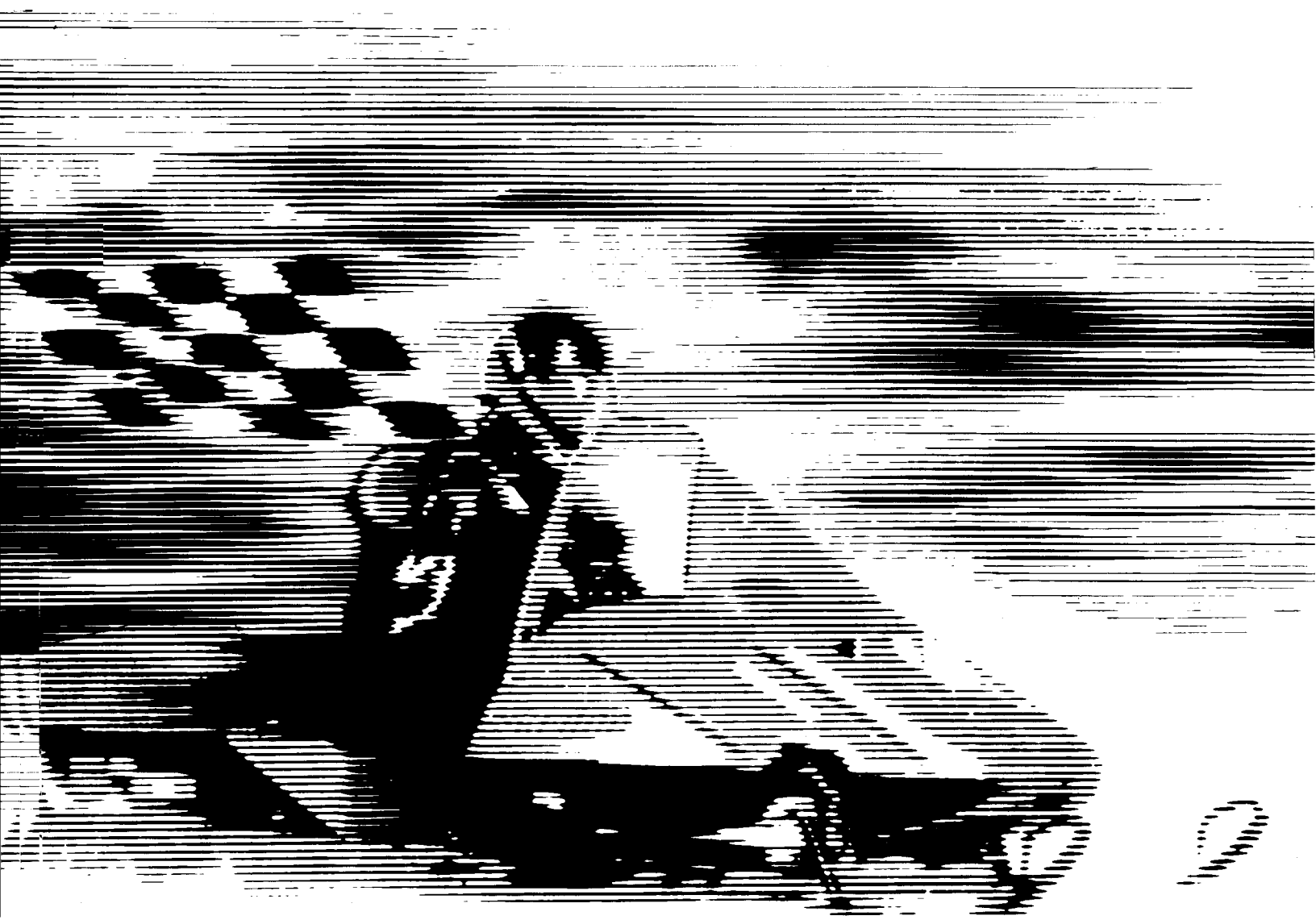

1988

model _____

V.I.N. _____

purchase date _____

warranty expiry date _____

To be completed by dealer at time of sale

DEALER IMPRINT AREA

AFTER SALES SERVICE
 BOMBARDIER INC.
 VALCOURT, QUEBEC
 CANADA, JOE 2LO



The following are trademarks of Bombardier Inc.

- | | | |
|--------------|---------------------|----------|
| ALPINE® | FORMULA* | SAFARI* |
| BLIZZARD® | FUTURA® | SKANDIC* |
| BOMBARDIER® | GRAND PRIX SPECIAL* | SKI-DOO® |
| CARRY-BOOSE® | MIRAGE* | SONIC* |
| CITATION® | MOTO-SKI® | SPIRIT* |
| ELAN® | NORDIK* | STRATOS* |
| ELITE® | NUVIK* | T'NT® |
| ESCAPADE® | OLYMPIQUE* | TUNDRA* |
| EVEREST® | ROTAX* | |

FOREWORD

The operator manual and the Snowmobile Safety Handbook have been prepared to acquaint the owner/operator of a new snowmobile with the various vehicle controls, maintenance and safe operating instructions. Each is indispensable for the proper use of the product, and should be kept with the vehicle at all times.

Should you have any questions pertaining to the warranty and its application, please consult the "Often Asked Question" section of this manual, or your authorized dealer.

This manual uses the following symbols.

◆ **WARNING:** Identifies an instruction which, if not followed, could cause personal injuries including possibility of death.

▼ **CAUTION:** Denotes an instruction which, if not followed, could severely damage vehicle components.

○ **NOTE:** Indicates supplementary information needed to fully complete an instruction.

Although the mere reading of such information does not eliminate the hazard, your understanding of the information will promote its correct use.

The information, illustrations and components/system descriptions contained in this manual are correct at time of publication. Bombardier Inc. however, maintains a policy of continuous improvement of its products without imposing upon itself any obligation to install them on products previously manufactured.

Bombardier Inc. reserves the right at any time to discontinue or change specifications, designs, features, models or equipment without incurring obligation.

The illustrations show the typical construction of the different assemblies and, in all cases, may not reproduce the full detail or exact shape of the parts shown, however, they represent parts which have the same or a similar function.

Most specifications are given in both metric and customary units. Where precise accuracy is not required, some conversions are rounded to even numbers for easier use.

◆ **WARNING:** The engines and the corresponding components identified in this manual should not be utilized on product(s) other than those mentioned on the cover page of this manual.

▼ **CAUTION:** Several components of this vehicle are built with parts dimensioned in the metric system. Most fasteners are metric and must not be replaced by customary fasteners or vice versa. Mismatched or incorrect fasteners could cause damage to the vehicle or possible personal injury.

SAFETY MEASURES

OBSERVE THE FOLLOWING PRECAUTIONS:

- Throttle mechanism should be checked for free movement before starting engine. The snowmobile engine can be stopped by activating the emergency cut out switch, tether switch or by turning off the key.
- Do not operate vehicle near snow making equipment.
- Engine should be running only when belt guard and/or pulley guard is secured in place.
- Never run the engine without drive belt installed. Running an unloaded engine can prove to be dangerous.
- Never run the engine when the track is raised off the ground.
- It can be dangerous to run engine with the hood removed.
- Gasoline is flammable and explosive under certain conditions. Always manipulate in a well ventilated area. Do not smoke or allow open flames or sparks in the vicinity. If gasoline fumes are noticed while driving, the cause should be determined and corrected without delay.
- Maintain your vehicle in top mechanical condition at all times.
- Your snowmobile is not designed to be driven or operated on black top, bare earth, or other abrasive surfaces. On such surfaces abnormal and excessive wear of critical parts is inevitable.
- Installation of other than standard equipment, including ski-spreaders, bumpers, pack racks, etc., could severely affect the stability and safety of your vehicle. Avoid adding on accessories that alter the basic vehicle configuration.
- Whenever the vehicle is parked outdoors, overnight or for a long period, it is suggested to protect it against the inclemency of the weather with a snowmobile cover.
- Do not lubricate throttle and/or brake cables and housings.
- Only perform procedures as detailed in this manual. Unless otherwise specified, engine should be turned OFF for all lubrication and maintenance procedures.
- Clean and check operation of the headlight, taillight and brake light.
- These vehicles are designed for the driver only. No provisions have been made for a passenger.
- Should removal of a nylon lock nut be required when undergoing repairs/disassembly, always replace by new ones.

PLEASE READ AND UNDERSTAND ALL WARNINGS AND CAUTIONS IN THIS MANUAL AND ON THE VEHICLE.

THIS MANUAL SHOULD REMAIN WITH THE VEHICLE AT THE TIME OF RESALE.

INDEX

PAGE

THE 1988 "LIMITED WARRANTY".....6

OFTEN ASKED QUESTIONS.....8

LISTING OF AREA DISTRIBUTORS.....10

HOW TO IDENTIFY YOUR SNOWMOBILE.....11

CONTROLS/INSTRUMENTS

Throttle lever, brake lever, gear shift lever, ignition/light switch, headlamp dimmer switch, emergency cut-out switch, tether cut-out switch, hot-grip switch, rewind starter handle, primer, adjustable steering handle, speedometer, fuel gauge/tank cap, hood opening, tool box, hitch.....12

BREAK-IN PERIOD

Engine and belt break-in, 10 hour-inspection, check list.....19

FUEL AND OIL

Recommended gasoline, recommended oil, fuel mixture ratio, fuel mixing procedure, fuel/oil mixing charts.....21

PRE-START CHECK

Check points.....25

STARTING PROCEDURE

Manual starting, before riding, emergency starting.....25

LUBRICATION

Frequency, steering mechanism, drive axle, slide suspension, drive pulley, gearbox oil level.....28

MAINTENANCE

Chart, belt guard removal, drive belt removal and installation, drive belt condition, new drive belt, brake condition, brake adjustment, spark plug, battery, suspension condition, suspension adjustment, track condition, track tension and alignment, drive pulley, drive chain tension, steering mechanism, steering adjustment, muffler attachment, engine head nuts, engine mount nuts, carburetor adjustment, fan belt, headlamp beam aiming, bulb replacement, general inspection.....31

INDEX (Con't...)

PAGE

STORAGE

Track, suspension, ski, controls, gearbox, drive pulley, engine and primer lubrication, fuel tank and carburetor, battery, chassis, general inspection.....50

PRE-SEASON PREPARATION

Pre-season preparation chart,.....56

TROUBLE SHOOTING GUIDE57

TOOLS61

SPECIFICATIONS62

WIRING DIAGRAMS64

SI METRIC INFORMATION GUIDE65

THE 1988 SNOWMOBILE LIMITED WARRANTY

1 - PERIOD

BOMBARDIER® INC. as manufacturer, warrants FROM THE DATE OF DELIVERY TO THE FIRST CONSUMER, every 1988 BOMBARDIER snowmobile, sold as NEW AND UNUSED, and predelivered by an authorized BOMBARDIER dealer for a period of:

- 12 consecutive months.

2 - WHAT BOMBARDIER WILL DO

BOMBARDIER will repair and/or replace, at its option, components defective in material and/or workmanship (under normal use and service), with a genuine BOMBARDIER component without charge for parts or labour, at any authorized BOMBARDIER dealer during said warranty period.

3 - CONDITION TO HAVE WARRANTY WORK PERFORMED

Present to the servicing dealer, the hard copy of the BOMBARDIER Warranty Registration card or proof of purchase received by the customer from the selling dealer at time of delivery.

4 - WARRANTY TRANSFER

This warranty is transferable to subsequent owner(s) for remainder of warranty period from original date of delivery.

5 - EXCLUSIONS - ARE NOT WARRANTED

- Normal wear on all items such as, but not limited to:
 - drive belts
 - bulbs
 - slider shoes
 - runners on skis
 - spark plugs
- Replacement parts and/or accessories which are not genuine BOMBARDIER parts and/or accessories.
- Damage resulting from installation of parts other than genuine BOMBARDIER parts.
- Damage caused by failure to provide proper maintenance as detailed in the Operator's Manual. The labour, parts and lubricants costs of all maintenance services, including tune-ups and adjustments will be charged to the owner.
- Vehicles designed and/or used for racing purposes.
- All optional accessories installed on the vehicle.
(The normal warranty policy for parts and accessories, if any, applies).
- Damage resulting from accident, fire or other casualty, misuse, abuse or neglect.
- Damage resulting from operation of the snowmobile on surfaces other than snow.
- Damage resulting from modification to the snowmobile not approved in writing by BOMBARDIER.
- Losses incurred by the snowmobile owner other than parts and labour, such as, but not limited to, transportation, towing, telephone calls, taxis, or any other incidental or consequential damage.

6 - BATTERY WARRANTY:

- 12 consecutive months. (Pro-rated)

100% warranty coverage will start on the date the snowmobile was delivered and run to the following April 30th. The remainder of the 12 month-period will be pro-rated as follows:

- 50% from April 30th to December 1st.
- 40% from December 1st to December 31st.
- 30% from January 1st to end of warranty.

7 - EXPRESSED OR IMPLIED WARRANTIES

This warranty gives you specific rights, and you may also have other legal rights which may vary from state to state, or province to province. Where applicable this warranty is expressly in lieu of all other expressed or implied warranties of BOMBARDIER, its distributors and the selling dealer, including any warranty of merchantability or fitness for any particular purpose; otherwise the implied warranty is limited to the duration of this warranty. However, some states or provinces do not allow limitations on how long an implied warranty lasts, so the above limitation may not apply.

Neither the distributor, the selling dealer, nor any other person has been authorized to make any affirmation, representation or warranty other than those contained in this warranty, and if made, such affirmation, representation or warranty shall not be enforceable against BOMBARDIER or any other person.

Some states or provinces do not allow the exclusion or limitation of incidental or consequential damages, so the above limitation or exclusion may not apply.

BOMBARDIER INC. reserves the right to modify its warranty policy at any time, being understood that such modification will not alter the warranty conditions applicable to vehicles sold while the above warranty is in effect.

8 - CONSUMER ASSISTANCE

If a servicing problem or other difficulty occurs, we suggest the following:

1. Try to solve the problem at the dealership with the Service Manager or Owner.
2. If this fails, contact your area distributor listed in the Operator's Manual.
3. Then if your grievance still remains unsolved, you may write to us:

Bombardier Inc.
Service Department
Recreational Products Division
Valcourt (Quebec), Canada JOE 2L0

September 1986
Bombardier Inc.
Valcourt (Quebec), Canada JOE 2L0
®* Trademarks of Bombardier Inc.

OFTEN ASKED QUESTIONS

Q: Why must my snowmobile be registered? After all I do have my original invoice as proof of when I purchased my snowmobile.

A: Your warranty is valid at any authorized dealer of the product. Your registration is the key element in providing the servicing dealer with the necessary data to complete warranty claim forms. This information is also used to notify owners in the event of a safety recall.

Q: Who should send the registration card to Bombardier Inc.?

A: The dealer. However, the customer must make sure that it has been sent. The company might contact you should your vehicle be recalled or in case of a particular warranty campaign.

Q: I bought my snowmobile in O'King County but I snowmobile in Washington county. Can the dealer in Washington County accept to perform warranty work on my snowmobile?

A: Yes, any authorized dealer in North America can perform warranty repairs, providing the customer warranty registration card is presented.

Q: Where can I find information on the lubrication and maintenance of my snowmobile?

A: In this Operator Manual provided with the vehicle at the time of first sale.

Q: Will the entire warranty be void or cancelled, if I do not operate or maintain my new snowmobile exactly as specified in the Operator's Manual?

A: The warranty of the new snowmobile cannot be "Voided" or "Cancelled". However, if a particular failure is caused by operation or maintenance other than is shown in the Operator Manual, THAT failure may not be covered under warranty. This includes service work performed by the customer, especially the critical adjustments to ignition, timing, carburation and oil injection/or oil mixture.

Q: Would you give some examples of abnormal use or strain, neglect or abuse?

A: These terms are general and overlap each other in areas. Some specific examples may include: running the machine out of oil, chain failure caused by a lack of lubrication, operating the machine with a broken or damaged part which causes another part to fail, and so on. If you have any specific questions on operation or maintenance, please contact your dealer for advice.

OFTEN ASKED QUESTIONS (Con't...)

Q: What costs are my responsibility during the warranty period?

A: The customer's responsibility includes all costs of normal maintenance services, non-warranty repairs, accidents and collision damage, as well as oils, and spark plugs, and incidental or consequential damages costs as explained in the warranty.

Q: Are "Genuine" Bombardier replacement parts used in warranty repairs covered by warranty?

A: Yes. When installed by an authorized dealer, any "genuine" Bombardier part used in warranty repairs assumes the remaining warranty that exists on the machine.

Q: If I sell my snowmobile within the warranty period, will the new owner qualify for the balance of the warranty?

A: Yes, provided the unit has already been registered with the manufacturer. Note that the change of ownership card in this manual should be completed and sent to Bombardier Inc.

Q: How can I receive the best owner assistance?

A: The satisfaction and goodwill of the owners of Bombardier products are of primary concern to your dealer and Bombardier Inc. Normally, any problems that arise in connection with the sales transaction or the operation of your snowmobile will be handled by your Dealers Sales or Service Departments. It is recognized, however, that despite the best intentions of everyone concerned, misunderstandings will sometimes occur. If you have a problem that has not been handled to your satisfaction through normal channels, we suggest that you discuss your problem with a member of dealership management. Frequently, complaints are the result of a breakdown in communications and can quickly be resolved by a member of the dealership management. If the problem already has been reviewed with the Sales Manager or Service Manager, contact the Dealer himself or the General Manager.

LISTING OF AREA DISTRIBUTORS

CANADIAN DISTRIBUTORS

Quebec Branch
1350 Nobel
Boucherville (Quebec) J4B 1A1
(514) 655-6121
Province of Quebec

Ontario Branch
230 Bayview Drive
Barrie (Ontario) L4N 4Y8
(705) 728-8600
Province of Ontario

Technical office
P.O. Box 7060
Riverview (New Brunswick) E1B 1V0
(506) 386-6117
Atlantic Region

BROOKS EQUIPMENT LIMITED
1616 King, Edward Street
P.O. Box 985
Winnipeg (Manitoba) R3C 2V8
**British Columbia, Manitoba,
Saskatchewan, Alberta, Yukon**

CHARLES R. BELL LIMITED
Newfoundland, Labrador
Offices
- Riverside Drive
P.O. Box 1050
Corner Brook (Newfoundland)
A2H 6J3 (709) 634-3533

-81 Kenmount Road
P.O. Box 8127
St-John's (Newfoundland)
A1B 3N1
(709) 722-6700

HUDSON'S BAY CO. LTD.
165 Hymus Blvd
Pointe-Claire (Quebec) H9R 1G2
(514) 697-8500
**North-West Territories, Franklin District &
Keewatin**

AMERICAN DISTRIBUTORS

BOMBARDIER CORPORATION
All States (excluding Alaska)

SERVICES OFFICES
- East Main Street Road
Malone, New York 12953
(518) 483-4411

Technical office
(506) 386-6117

- 4505 West Superior Street
P.O. Box 16106
Duluth, Minnesota 55816-0106
(218) 628-2881

- P.O. Box 1569
Idaho Falls, Idaho, 83403
(208) 529-9510

NATIONAL SALES OFFICE
- O'Hare Lake Plaza
2350 Devon Avenue
Suite 150
Des Plaines, Illinois 60018
(312) 298-9540

MILLER EQUIPMENT AND
RECREATIONAL CENTER
1049 Whitney Road
Anchorage, Alaska 99501
(907) 274-9513
Alaska

HOW TO IDENTIFY YOUR SNOWMOBILE

The main components of your snowmobile (engine, track(s) and frame) are identified by different serial numbers. It may sometimes become necessary to locate these numbers for warranty purposes or to trace your snowmobile in the event of theft.

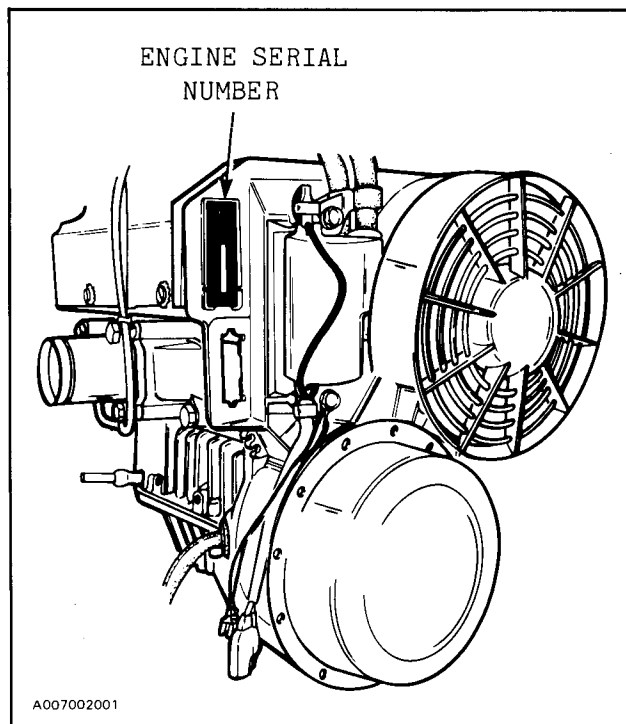
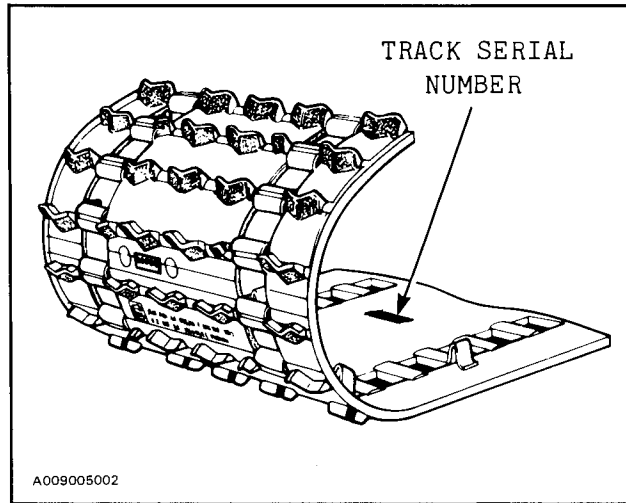

VEHICLE SERIAL NUMBER is located in the backcorner of the frame and at the right hand side under the hood.

○ **NOTE:** We strongly recommend that you take note of all the serial numbers on your vehicle and supply them to your insurance company. It will surely help in the event a snowmobile is stolen.

CONTROLS/INSTRUMENTS

NORDIK 50

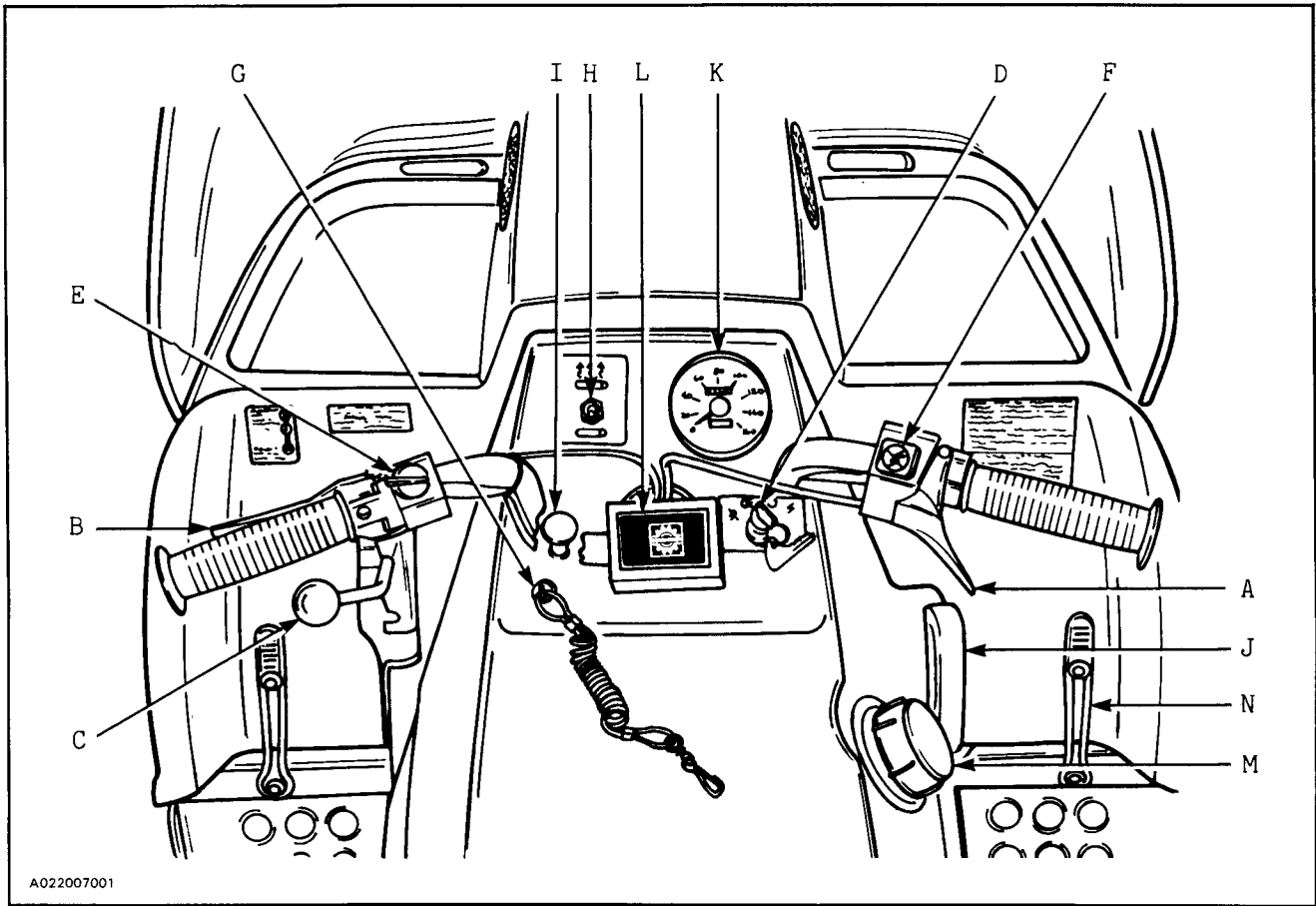

- A) Throttle lever
- B) Brake lever
- C) Gear shift lever
- D) Ignition/light switch
- E) Headlamp dimmer switch
- F) Emergency cut-out switch
- G) Tether cut-out switch
- H) Hot grips switch
- I) Primer
- J) Rewind starter handle
- K) Speedometer
- L) Steering handle
- M) Fuel guage/Tank cap
- N) Hood opening

CONTROLS/INSTRUMENTS

NORDIK 60

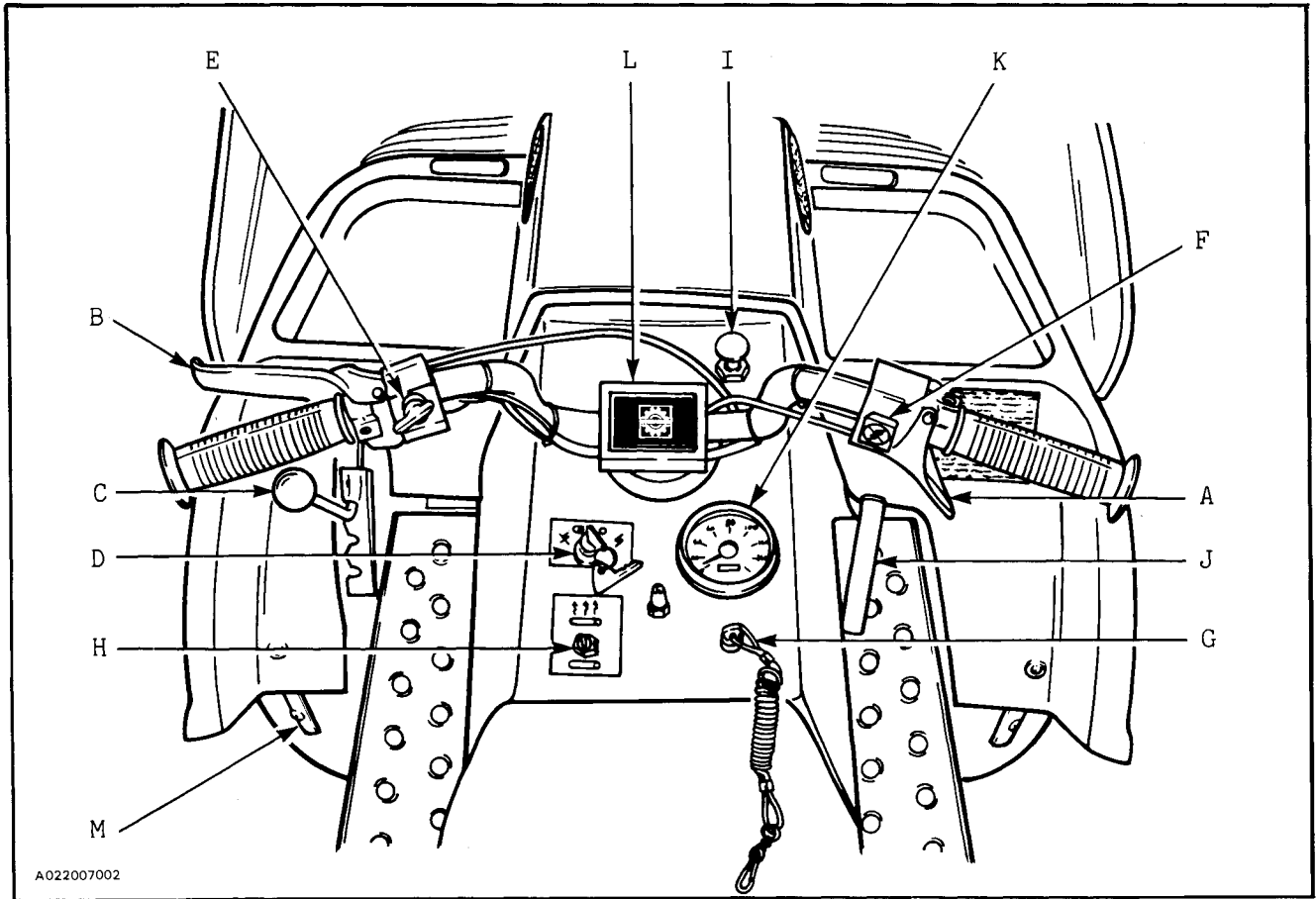

- A) Throttle lever
- B) Brake lever
- C) Gear shift lever
- D) Ignition/light switch
- E) Headlamp dimmer switch
- F) Emergency cut-out switch
- G) Tether cut-out switch
- H) Hot grips switch
- I) Primer
- J) Rewind starter handle
- K) Speedometer
- L) Steering handle
- M) Hood opening
- N) Fuel guage/Tank cap (under seat)

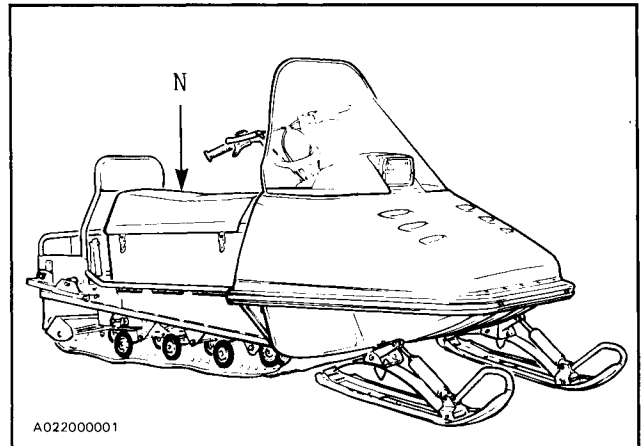

A) THROTTLE LEVER

Located on right side of handlebar. When compressed, it controls the engine speed and the engagement of the transmission. When released, engine speed returns automatically to idle.

B) BRAKE LEVER

Located on the left side of handlebar. When compressed, the brake is applied. When released, it automatically returns to its original position. Braking effect is proportionate to the pressure applied on the lever and to the type of terrain and its snow coverage.

C) GEAR SHIFT LEVER

3 positions: 2 forward
and 1 reverse

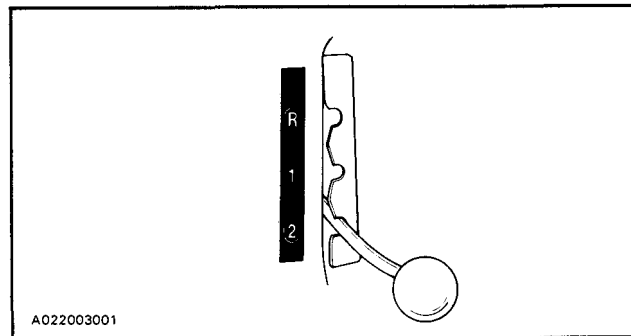

◆ **WARNING:** This snowmobile is capable of a fast reverse. On first outing, operator should become familiar with this operation by practicing on level ground. Always apply the brake before shifting and come to a complete stop then while holding brake on, change gear. This is particularly important while on a slope. Ensure the path behind is clear of obstacles or bystanders. Fast reverse, while turning, could result in loss of stability.

D) IGNITION/LIGHT SWITCH

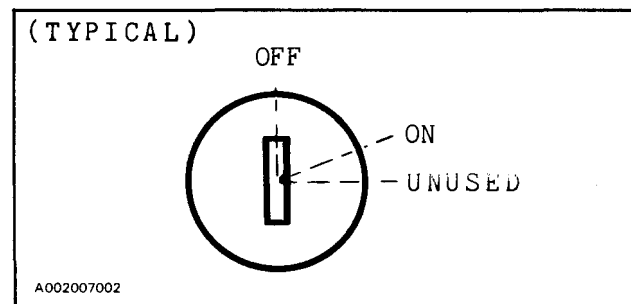

Key operated, 3 position switch. To start engine, turn key clockwise to ON position. To stop engine, turn key counter-clockwise to OFF position.

The 3rd position is not in use.

The lights are automatically ON whenever the engine is running.

E) HEADLAMP DIMMER SWITCH

The dimmer switch, located on left side of handlebar, allows correct selection of headlamp beam. To obtain high or low beam simply flick switch.

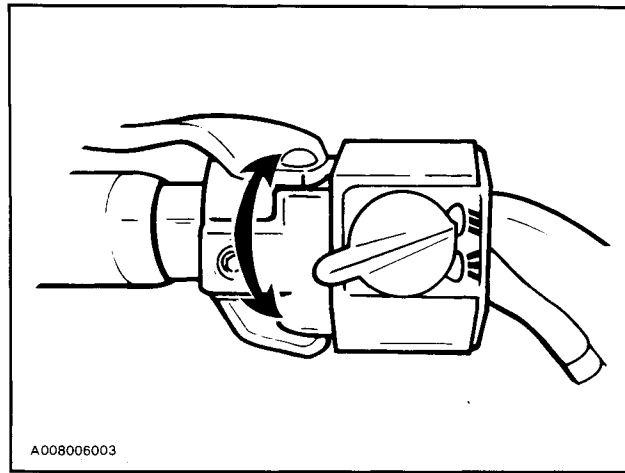

F) EMERGENCY CUT-OUT SWITCH

A push pull type switch located on the right side of the handlebar. To stop the engine in an emergency, push the button to the lower off position and simultaneously apply the brake. To start engine, button must be at the upper ON position.

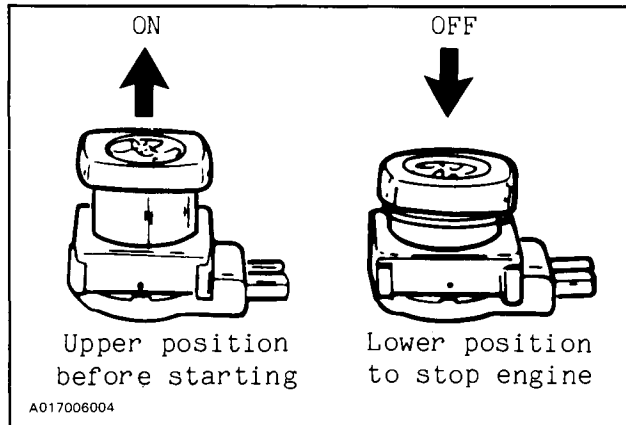

The driver of this vehicle should familiarize himself with the function of this device by using it several times on first outing. Thereby being mentally prepared for emergency situations requiring its use.

◆ **WARNING:** For safety reasons, the emergency cut-out switch is easily accessible; be careful not to operate it inadvertently. If the switch has been used in an emergency situation the source of malfunction should be determined and corrected before restarting engine.

G) TETHER CUT-OUT SWITCH

Attach tether cord to wrist or other convenient location then snap tether cut-out cap over receptacle before starting engine.

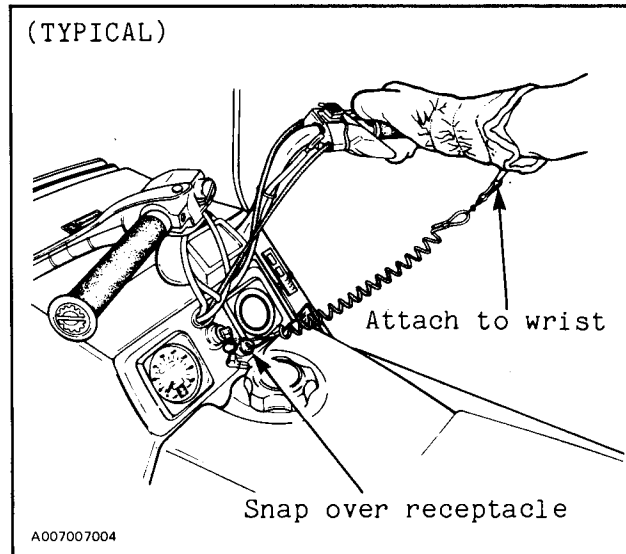

If emergency engine "shut off" is required, completely pull cap from safety switch and engine power will be automatically shut "off".

○ **NOTE:** The cap must be installed on the safety switch at all times in order to operate the vehicle.

◆ **WARNING:** If the switch is used in an emergency situation the source of malfunction should be determined and corrected before restarting engine.

H) HOT GRIP SWITCH

The hot grip switch is located on the instrument panel. To engage hot grips flick the lever to ON position. (Ignition switch must be turned to LIGHT position.)

I) PRIMER

A push-pull button. Pull and push button (2-3 times) to activate primer. The primer should always be used for cold engine starts. After engine is warm however, it is not necessary to use primer when starting.

J) REWIND STARTER HANDLE

Auto rewind type located on right hand side of vehicle. To engage mechanism, pull handle.

K) SPEEDOMETER

The speedometer is linked directly to the drive axle. Direct-reading dial indicates the speed of the vehicle. Odometer records the total distance travelled in kilometers.

The trip meter reset button is located on the speedometer housing. To reset, turn black knob, until all numbers read zero.

L) TO ADJUST STEERING HANDLE

- Remove steering cover.
- Loosen the four (4) retaining screws.
- Adjust the handle to the desired position.

◆ **WARNING:** Do not adjust too high as the brake lever may contact the windshield when turning.

- Lock the steering handle in place by tightening the four (4) retaining screws to 26 N·m (19 lbf·ft).
- Reinstall steering cover.

M) FUEL GAUGE/TANK CAP

Unscrew fuel tank cap and withdraw dipstick to check fuel level.

◆ **WARNING:** Never use a lit match or open flame to check fuel level.

○ **NOTE** Nordik 60 fuel gauge/tank cap is located under the seat.

N) HOOD OPENING

Nordik 50, pull down the latches to unlock the hood from the anchor. Nordik 60, pull up the latches to unlock the hood from the anchor.

○ **NOTE:** Always lift hood gently up until stopped by restraining device.

◆ **WARNING:** It is dangerous to run an engine with the hood open unfastened or removed.

TOOL BOX

Located under the seat to gain access, tilt seat. Ideal location for spare rope, first aid kit, etc.

HITCH

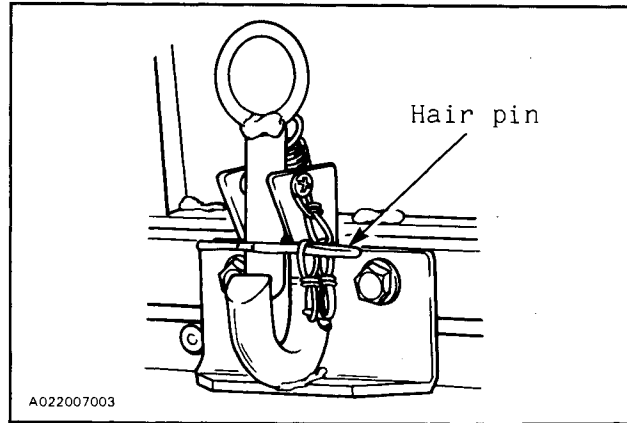

Fixed on the frame. A hair pin is supplied to lock the hook attachment.

◆ **WARNING:** When towing a sled or trailer, always ensure to lock the hook attachment with the hair pin.

(NORDIK 60)

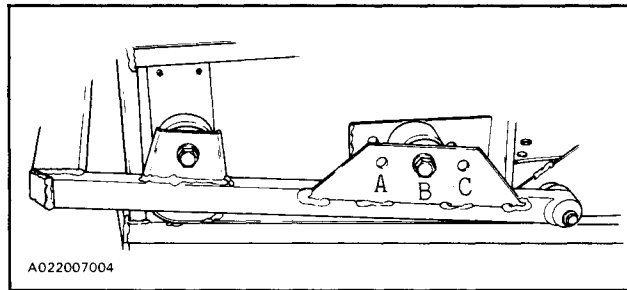

Fixed on the draw bar installed with rubber mounts on the frame.

The hitch is adjustable in accordance with the load. When pulling heavy loads the position of the rubber mount can be adjusted to holes A in order to improve maneuverability of the snowmobile. When pulling light loads the attachment can be changed to holes C to increase hitch travelling. The original attachment point is hole B.

◆ **WARNING:** When towing a sled or trailer, always ensure to lock the hook attachment with the hair pin.

Trailers or sleds towed behind a snowmobile should always be loaded in a way to obtain the lowest possible center of gravity. Use a rigid tow bar when pulling a tow sled behind snowmobile. When you are pulling passengers in a trailer or tow sled, use moderate speed and avoid rough terrain for their safety. Also, have all passengers get out of a towed vehicle and walk across all roads.

BREAK IN PERIOD

ENGINE

With Bombardier-Rotax snowmobile engines, a break-in period is required before running the vehicle at full throttle. Engine manufacturer recommendation is 10 to 15 operating hours. During this period, a richer mixture is needed (i.e. 40 parts of gas for 1 part of BLIZZARD oil). Maximum throttle should not exceed $3/4$, however, brief full acceleration and speed variations contribute to a good break-in. Continued wide open throttle accelerations, prolonged cruising speeds, and lugging are detrimental during the break-in period.

○ **NOTE:** For the break-in period only, 450 ml (16 oz) of Bombardier Snowmobile Injection oil should be added to fuel for the first full fuel tank filling.

This will assure additional protection during the initial engine break-in.

▼ **CAUTION:** Remove and clean spark plug after engine break-in.

BELT

A new drive belt requires a break-in period of 25 km (15 miles).

10-HOUR INSPECTION

As with any precision piece of mechanical equipment, we suggest that after the first 10 hours of operation or 30 days after the purchase, whichever comes first, that your vehicle be checked by your dealer. This inspection will give you the opportunity to discuss the unanswered questions you may have encountered during the first hours of operation. Remember that it is easier to remedy at this time than to allow the snowmobile to operate until a possible failure occurs.

The 10 hour inspection is at the expense of the vehicle owner.

10-HOUR INSPECTION CHECKLIST	✓
Engine timing	
Fan belt tension	
Spark plugs condition: (Remove and clean)	
Carburetor adjustment	
Engine head nuts	
Engine mount nuts	
Muffler attachment	
Gearbox oil level	
Chain tension	
Brake operation and lining condition	
Skis alignment (runners condition)	
Steering arm retorque to: 60 N·m (44 lbf·ft)	
Handlebar bolts, retorque to 26 N·m (19 lbf·ft)	
Pulley alignment and drive belt condition	
Drive pulley screw torque	
Track condition, tension and alignment	
Lubricate (steering, suspension, drive axle)	
Electrical wiring (loose connections, stripped wires, damaged insulation), tighten all loose bolts, nuts and linkage	
Operation of lighting system (HI/LO beam, brake light, etc.), test operation of emergency cut-out switch and tether switch	

WE RECOMMEND THAT YOU HAVE YOUR DEALER SIGN THIS INSPECTION LIST.

Date of 10 hour inspection

Dealer signature

FUEL & OIL

Oil must be added to the gasoline in premeasured amounts then both oil and gasoline should be thoroughly mixed together before fueling the tank.

RECOMMENDED GASOLINE

Use regular leaded or unleaded gasoline available from all service stations.

▼ **CAUTION:** Never experiment with different fuels or fuel ratios. The use of gasoline containing alcohol such as methanol, ethanol (commonly called gasohol) or similar products including naphta is not recommended. The use of gasoline containing alcohol can result in vehicle performance deterioration and damage to critical parts in the fuel system and engine components.

◆ **WARNING:** Never 'top up' the gas tank before placing the vehicle in a warm area. At certain temperatures, gasoline will expand and overflow. Always wipe off any gasoline spillage from the snowmobile.

RECOMMENDED OIL

Use "BLIZZARD OIL" (P/N 496 0135 00-500 ml) available from your dealer. This type of oil will flow at temperatures as low as minus 40°C (-40°F).

It is a blend of specially selected base oils and additives which provides outstanding lubrication, engine cleanliness and minimum spark plug fouling.

If "BLIZZARD OIL" is unavailable, substitute with "Bombardier injection oil" (P/N 496 0133 00-1 liter).

▼ **CAUTION:** Never use outboard or straight minerals oils.

FUEL MIXTURE RATIO

The importance of using the correct fuel mixture cannot be overstressed. An incorrect fuel ratio results in serious engine damage. Recommended fuel ratio is 50:1 (40:1 during break-in period).

SI UNITS

500 ml oil to 25 liters = 50:1

IMPERIAL UNITS

16 oz oil to 5 imp. gals = 50:1

or

500 ml oil to 5 ½ imp. gals = 50:1

U.S. UNITS

12 oz oil to 5 U.S. gals = 50:1



NOTE: To facilitate fuel mixing, oil should be kept at room temperature.

FUEL MIXING PROCEDURE

To mix the gasoline and oil always use a separate clean container. Never mix directly in your snowmobile tank. For best results, acquire two containers, either plastic or metal. Draw from one until empty then use the second one.



WARNING: Gasoline is flammable and explosive under certain conditions. Always manipulate in a well ventilated area. Do not smoke or allow open flames or sparks in the vicinity. If gasoline fumes are noticed while driving, the cause should be determined and corrected without delay. Never add fuel while the engine is running. Avoid skin contact with fuel at below freezing temperatures.

1. Pour approximately 4 liters (one gallon) of gasoline into a clean container.

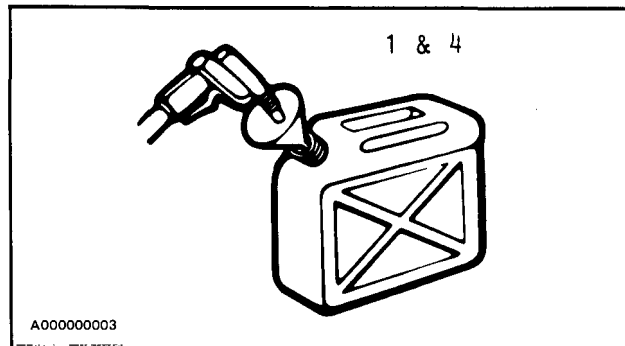

2. Add the full amount of oil required.

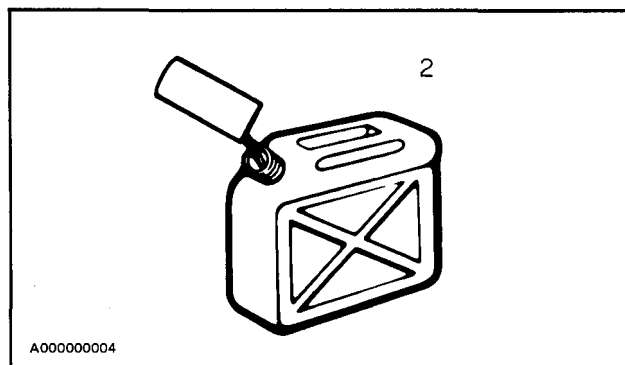

3. Replace the container cap and shake the container thoroughly.

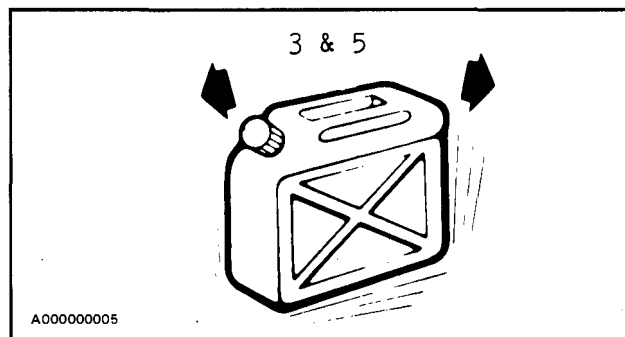

4. Add the remainder of the gasoline.
5. Once again thoroughly agitate the container. Then using a funnel with a fine mesh screen to prevent the entry of foreign particles, pour the mixture into the snowmobile tank.

◆ **WARNING:** To prevent fuel spillage in the engine compartment, a funnel must always be used when filling the gas tank.

○ **NOTE:** When using pre-mixed fuel, always shake the container thoroughly as the oil has a tendency to settle.

FUEL/OIL MIXING CHARTS
 (50 to 1 ratio)

METRIC (SI)

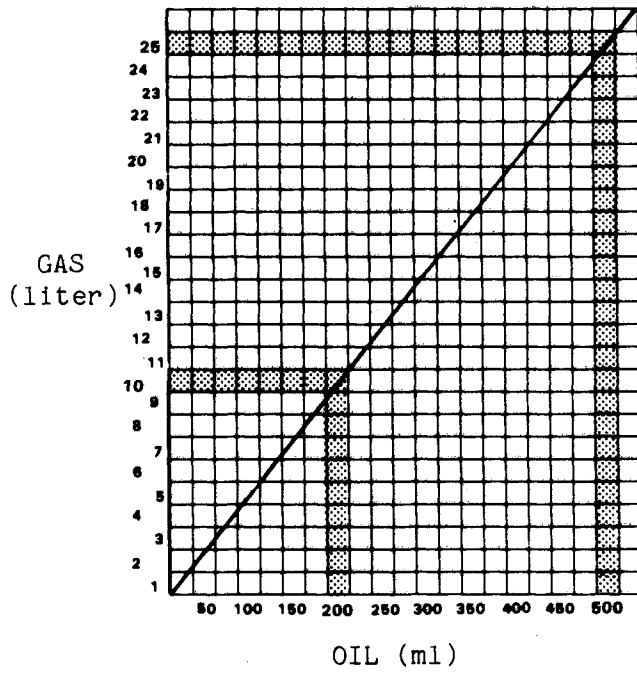

IMPERIAL

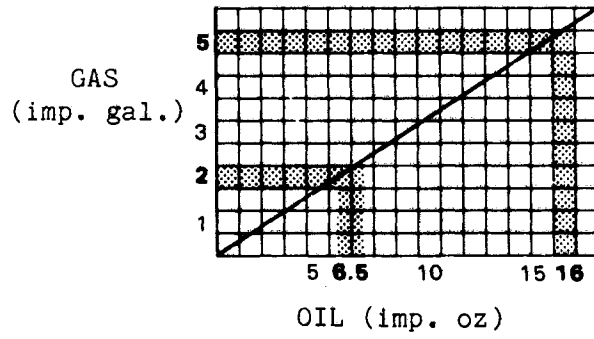

UNITED-STATE

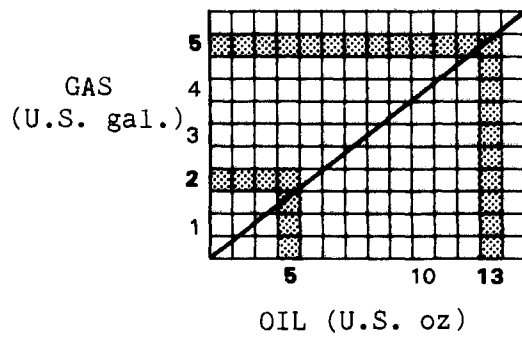

A00000006

PRE-START CHECK

CHECK POINTS

- ACTIVATE THE THROTTLE CONTROL LEVER SEVERAL TIMES to check that it operates easily and smoothly. The throttle control lever must return to idle position when released.
- Check fuel level.
- Check that the skis and the track are not frozen to the ground or snow surface and that steering operates freely.
- Activate the brake control lever and make sure the brake fully applies before the brake control lever touches the handlebar grip.
- Verify that the path ahead of the vehicle is clear of bystanders and obstacles.
- Clean and check operation of the headlight, taillight and brake light.
- Check position of gearshift lever.

◆ **WARNING:** Only start your snowmobile once all components are checked and functioning properly.

STARTING PROCEDURE

Test throttle control lever.

Check that the emergency cut-out switch is in the ON position.

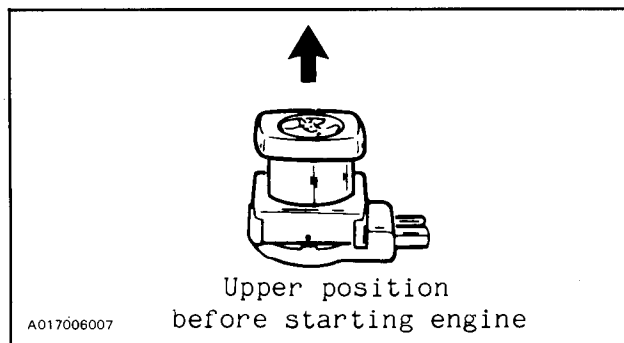

Ensure the tether cut-out cap is in position and that the cord is attached to your clothing.

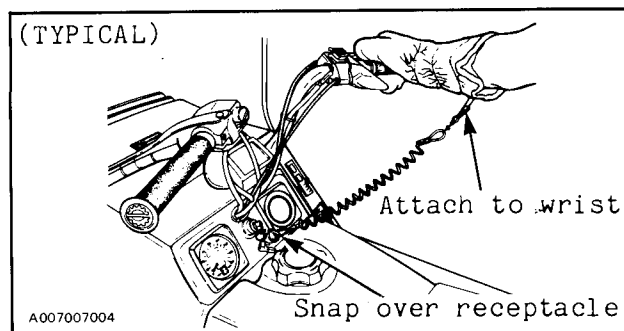

Activate the primer (2 or 3 times).

○ **NOTE:** The use of the primer is not necessary when the engine is warm.

MANUAL STARTING

Insert the key in the ignition and turn to ON position.

Grasp manual starter handle firmly and pull slowly until a resistance is felt then pull vigorously. Slowly release the rewind starter handle.

◆ **WARNING:** Do not apply throttle while starting.

BEFORE RIDING

Check operation of the emergency cut-out switch and tether switch.
Restart engine.

◆ **WARNING:** If engine does not shut-off when applying the emergency cut-out switch and or when pulling the tether cut-out cap, stop the engine by turning off the ignition key. Do not operate the vehicle further, see the dealer.

Allow the engine to warm before operating at full throttle.

EMERGENCY STARTING

Should the rewind starter rope fray and break, the engine can be started with an emergency starter rope.

◆ **WARNING:** Do not start the vehicle by the drive pulley unless it is a true emergency situation, have the vehicle repaired as soon as possible.

◆ **WARNING:** Do not wind starting rope around your hand. Hold rope by the handle only.

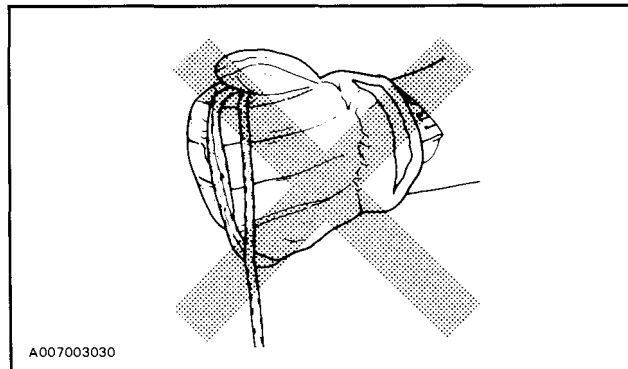

Remove the belt guard from the vehicle and wind the emergency rope tight around the drive pulley.

Start the engine as per usual manual starting.

◆ **WARNING:** When starting the vehicle in an emergency situation by the drive pulley, do not make a knot at the end of the emergency rope and do not reinstall the belt guard.

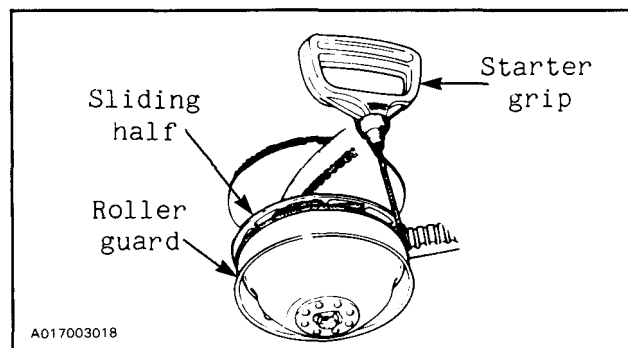

LUBRICATION

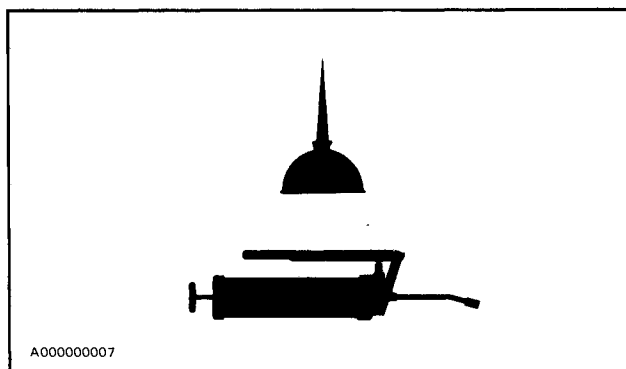

FREQUENCY

Routine maintenance is necessary for all mechanized products, and the snowmobile is no exception. A weekly vehicle inspection contributes to the life span of the snowmobile as well as retains dependable operation.

◆ **WARNING:** Only perform such procedures as detailed in this manual. It is recommended that dealer assistance be periodically obtained on other components/systems not covered in this manual. Unless otherwise specified, engine should be turned OFF for all lubrication and maintenance procedures.

It is recommended that the steering system and suspension be lubricated monthly or every 40 hours of operation. If the vehicle is operated in wet snow or in severe conditions these items should be lubricated more frequently.

◆ **WARNING:** Do not lubricate throttle and/or brake cables and housings.

STEERING MECHANISM

Lubricate the ski legs at grease fittings until new grease appears at joints. Coat spring slider cushion with grease.

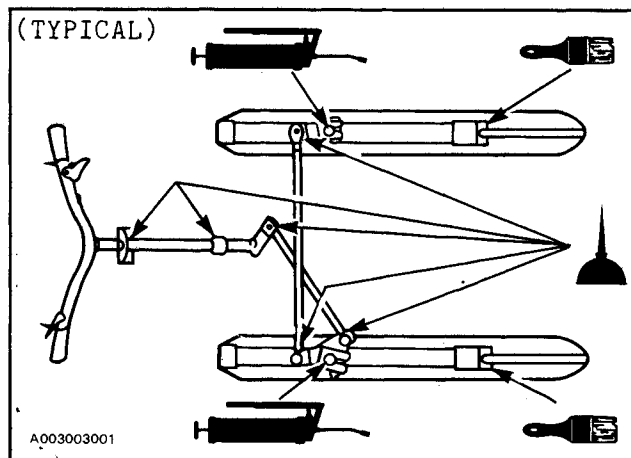

Oil spring coupler bolts, ball joints and steering column bushings.

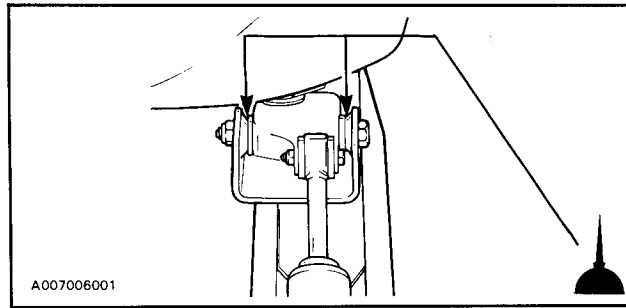

DRIVE AXLE

Lubricate at grease fitting using low temperature grease.

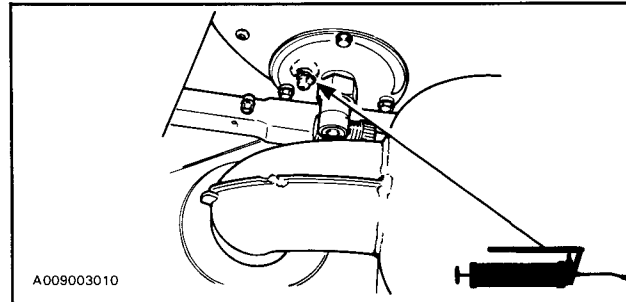

▼ **CAUTION:** When lubricating the drive axle bearing, do not apply excessive grease as the seal will be pushed out of its housing. Check seal position with finger.

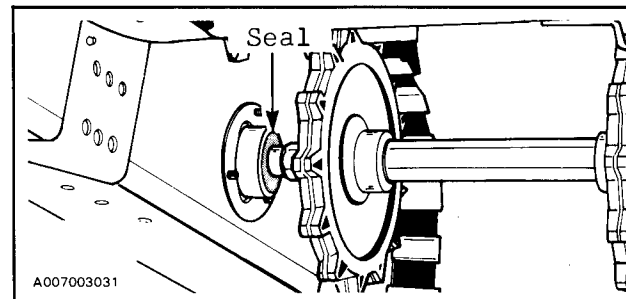

SLIDE SUSPENSION

(NORDIK 50 ONLY)

Also lubricate front & rear arms at grease fittings until grease appears at joints. Use low temperature grease only.

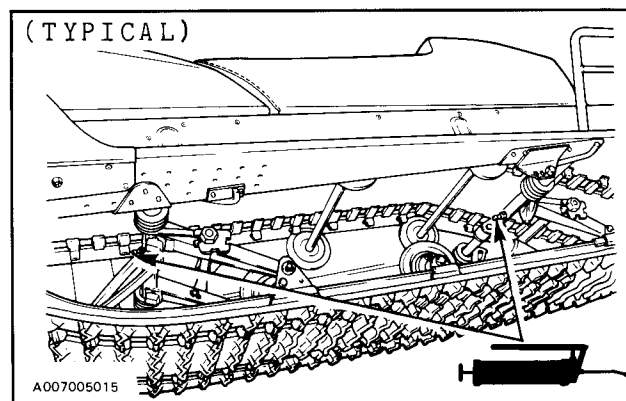

DRIVE PULLEY

Inspect the Duralon bushing condition by checking the free-play of the sliding half pulley. This is achieved by restraining the inner half and checking if the sliding half moves in the direction of the arrows more than 3 mm (1/8"). If so, contact the dealer.

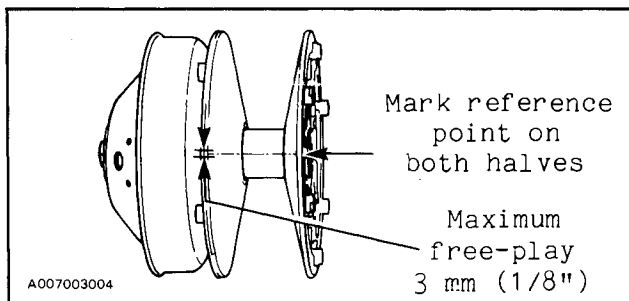

◆ **WARNING:** The drive pulley should be inspected by an authorized dealer at least annually.

GEARBOX OIL LEVEL

The gearbox oil capacity is 450 mL.

Check the oil by removing the chaincase plug.

The oil should be level with the bottom of the oil level orifice.

Remove rubber inspection cover located on bottom right side of gearbox. Using a rigid piece of wire as dipstick, check oil level. Oil level must reach 82 mm (3 1/4") on dipstick.



To fill, remove filler cap from top of gearbox. Refill as required using Bombardier chaincase oil.

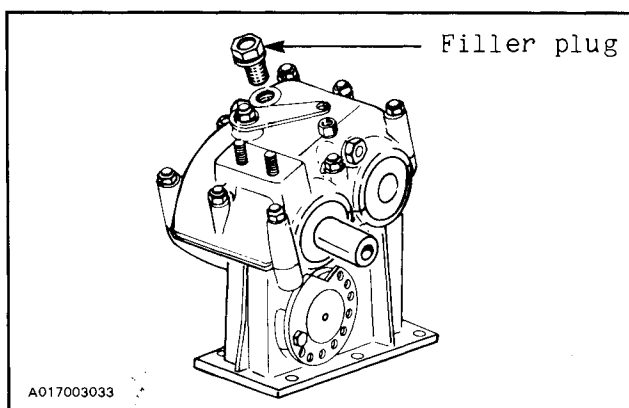

The following Maintenance Chart indicates regular servicing schedules to be performed by you or your servicing dealer. If these services are performed as suggested, your snowmobile will give you many years of low-cost use.

◆ **WARNING:** Only perform such procedures as detailed in this manual. It is recommended that dealer assistance be periodically obtained on other components/systems not covered in this manual. Unless otherwise specified, engine should be turned OFF for all lubrication and maintenance procedures.

MAINTENANCE CHART	Weekly or every 240 km (150 mi)	Monthly or every 800 km (500 mi)	Once a year or every 3200 km (2000 mi)	Refer to page
Drive belt condition	•			33
Brake condition	•			34
Brake adjustment		•		34
Spark plugs		•		35
Suspension condition		•		35
Suspension adjustment	(as required)			36
Track condition		•		38
Track tension and alignment		•		38
Drive pulley		•		30
Drive chain tension		•		42
Steering mechanism		•		42
Steering adjustment		•		43
Muffler attachment		•		44
Engine head nuts			•	44
Engine mount nuts			•	45
Carburetor adjustment			•	45
Fan belt			•	46
Headlamp beam aiming			•	46
General inspection		•		48

○ **NOTE:** The ten hour inspection is a very important part of proper service and maintenance.

BELT GUARD REMOVAL

◆ **WARNING:** Engine should be running only when belt guard is secured in place.

1. Tilt the hood.
2. Pull out both retaining pins.

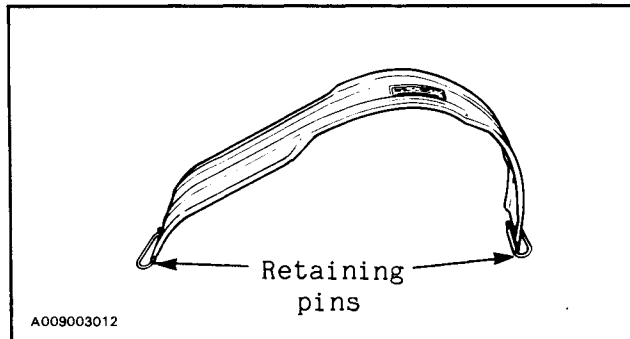

3. Lift and remove the belt guard assembly.

DRIVE BELT REMOVAL AND INSTALLATION

◆ **WARNING:** Never start or run engine without the drive belt installed. Running an unloaded engine is dangerous.

1. Tilt the hood and remove the pulley guard.
2. Open the driven pulley by twisting and pushing the sliding half. Hold in fully open position.

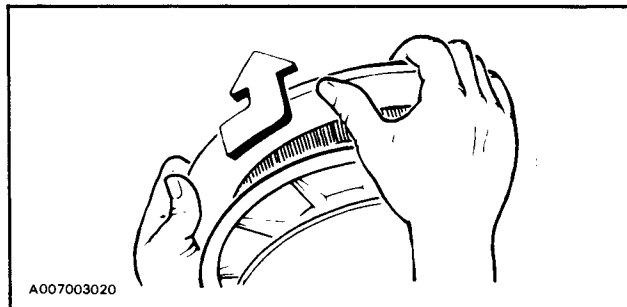

3. Slip the belt over the top edge of the sliding half.

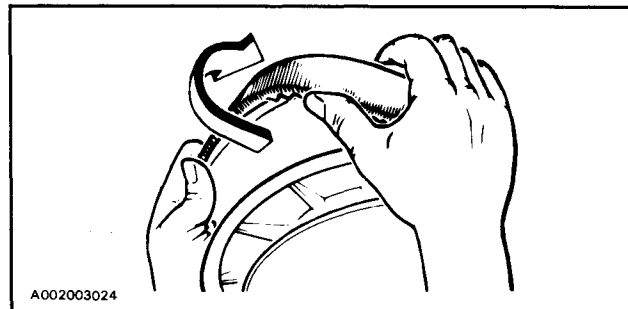

4. Slip the belt out from the drive pulley and remove completely from the vehicle. To install the drive belt, reverse the procedure, however pay attention to the following.

The maximum drive belt life span is obtained when the belt has the proper rotation direction. Install it so the printed information on the belt is in the way to be read when standing face to pulleys.

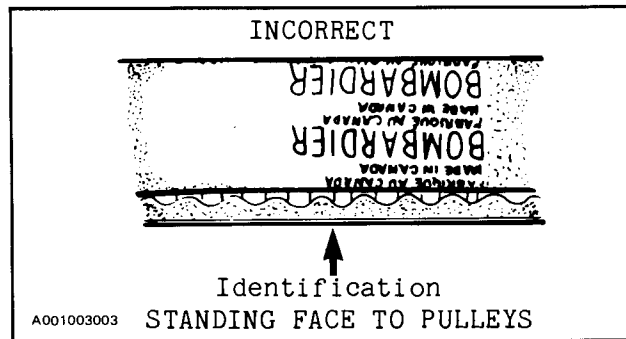
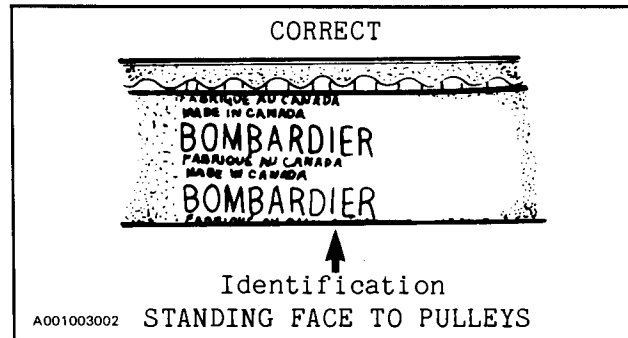

▼ **CAUTION:** Do not force or use tools to pry the belt into place, as this could cut or break the cords in the belt.

DRIVE BELT CONDITION

Inspect belt for cracks, fraying or abnormal wear (uneven wear, wear on one side, missing cogs, cracked fabric). If abnormal wear is noted, probable cause could be pulley misalignment, excessive R.P.M. with frozen track, fast starts without warm-up period, burred or rusty sheave, oil on belt or distorted spare belt. Contact your dealer.

Check the drive belt width.

Replace the drive belt if width is less than 31 mm (1¼ in).

NEW DRIVE BELT

When installing a new drive belt, break-in period of 25 km (15 miles) is strongly recommended.

○ **NOTE:** Always store a spare belt in a manner to allow its natural shape to be maintained.

BRAKE CONDITION

The brake mechanism on your snowmobile is an essential safety device. Keep this mechanism in proper working condition. Above all, do not operate your snowmobile without an effective brake system.

◆ **WARNING:** Brake pads must be replaced as soon as only 1 mm (1/32") of the fixed lining is still projected out of caliper. Replacement must be performed by an authorized dealer.

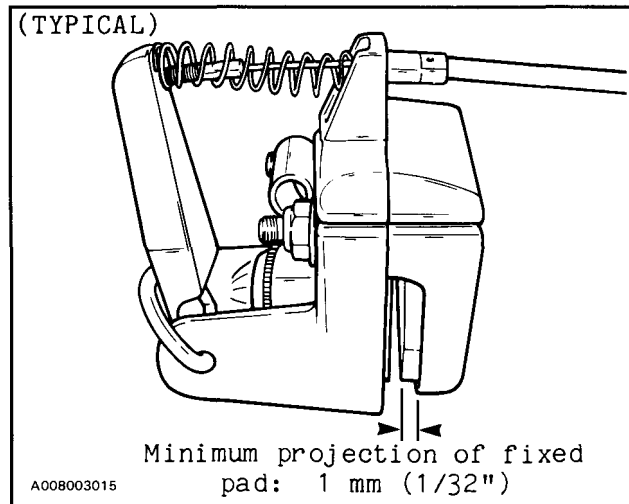

BRAKE ADJUSTMENT

The brake mechanism is a self-adjusting type. If a quicker brake response is desired, strongly pull the brake lever several times, this will actuate the self adjusting mechanism.

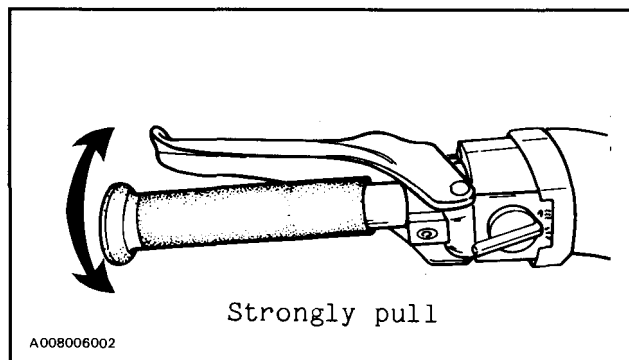

After the adjustment, brake should apply fully when lever is approximately 13 mm (1/2") from handlebar grip. If not, do not tamper with the brake, contact your servicing dealer.

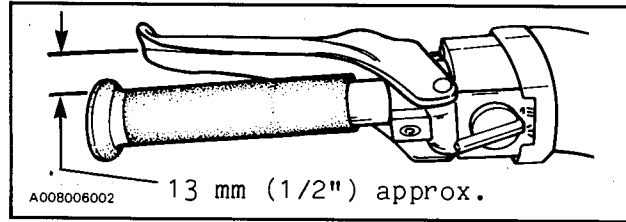

SPARK PLUGS

Disconnect the spark plug wires and remove the spark plugs.

Check the condition of the plugs.

- A brownish tip reflects ideal conditions. (Carburetor adjustment, spark plug heat range, etc., are correct.)
- A black insulator tip indicates fouling caused by: carburetor idle speed mixture and/or high speed mixture too rich, incorrect fuel mixture ratio, wrong type of spark plug (heat range), or excessive idling.
- A light grey insulator tip indicates a lean mixture caused by: carburetor high speed mixture adjusted too lean, wrong spark plug heat range, incorrect fuel mixture ratio, or a leaking seal of gasket.

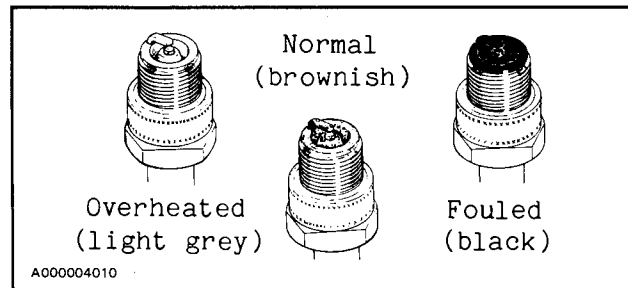

▼ **CAUTION:** If spark plug condition is not ideal, contact your authorized dealer.

Check spark plug gap using a wire feeler gauge.
Reinstall plugs and connect wires.

SUSPENSION CONDITION

(NORDIK 50)

Visually inspect all suspension components including slider shoes, springs, wheels, etc.

○ **NOTE:** During normal driving, snow will act as a lubricant and coolant for the slider shoes. Extensive riding on ice or sanded snow, will create excessive heat build-up and cause premature slider shoe wear.

(NORDIK 60)

Visually inspect suspension springs. Replace any weak or broken spring.

Check for wear or looseness. Correct as required.

SUSPENSION ADJUSTMENT

(NORDIK 50)

The suspension is adjustable, the front adjustment for surface condition, the rear for driver's weight.

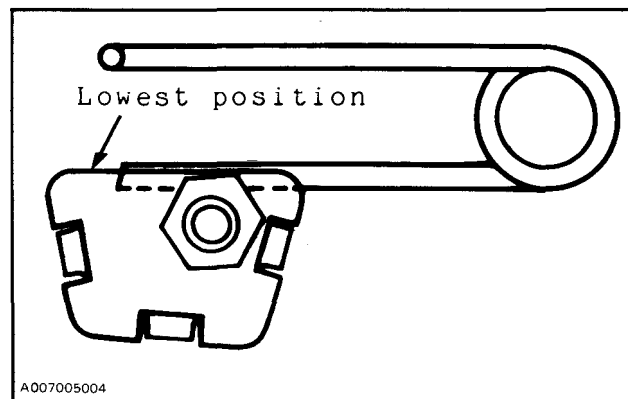
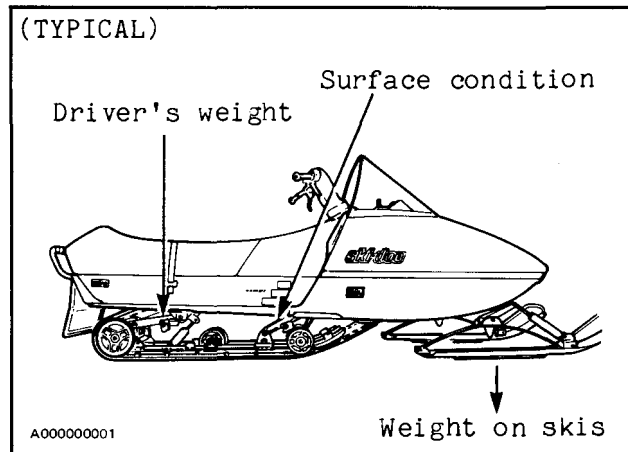

At the lowest position the weight is transferred to the skis.

At the highest position the weight is transferred to the track.

The rear adjuster blocks should be adjusted to suit the driver's preference.

▼ **CAUTION:** Left and right adjuster blocks of each adjustment must always be equally set.

○ **NOTE:** For deep snow condition or hill climbing, it is recommended to place the front adjuster blocks at the lowest position.

Additional deep snow and for hill climbing adjustment is possible by relocating the front arm cross shaft to the lower hole (B).

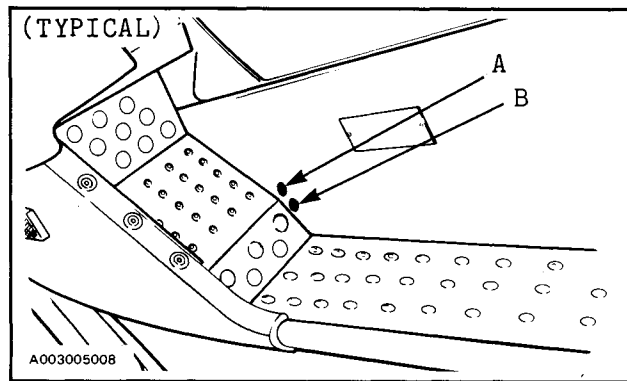

▼ **CAUTION:** Left and right cross shaft bolts must always be set at the same elevation.

◆ **WARNING:** Always torque cross shaft bolts to 69 N·m (52 lbf·ft).

More adjustment is possible when tightening or loosening the rear arm adjusting screw. Setting of distance A should be as follows:

DISTANCE A	CONDITIONS
10 mm	Soft snow Low weight
30 mm	Packed snow Heavy load

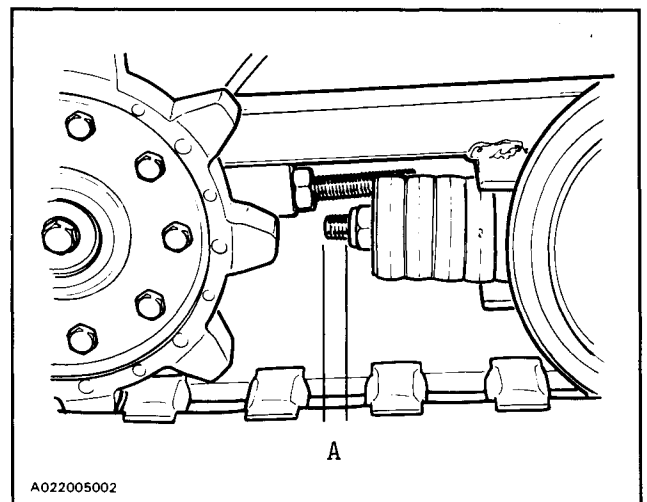

(NORDIK 60)

Lowering the attachment of the front bogie wheel set increases the ability to move in deep snow or high climbing. Holes are located approximately 15 mm (5/8") below the original cross shaft holes of the frame.

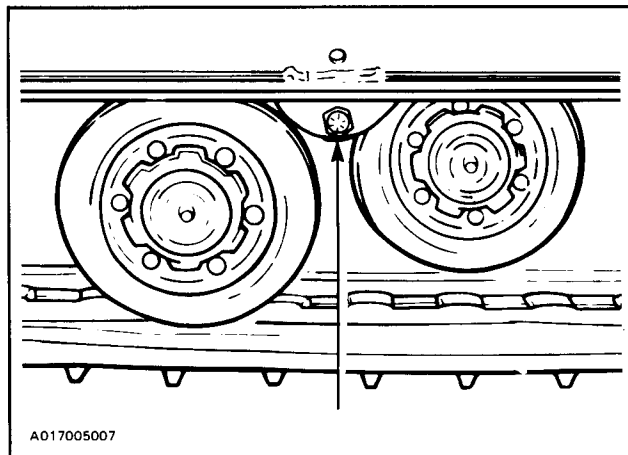

TRACK CONDITION

Lift rear of vehicle and support it off the ground. (Place gear shift lever in forward position). With the engine OFF, rotate track manually and inspect condition. If worn or cut, or if track fibers are exposed, or if missing or defective inserts are noted; contact your dealer.



WARNING: Do not operate a snowmobile with a cut, torn or damaged track.

TRACK TENSION AND ALIGNMENT

(NORDIK 50)

TENSION:

Lift the rear of vehicle and support with a mechanical stand. Allow the slide to extend normally. Check the gap between the slider shoe and the bottom inside of the track. If the track tension is too loose, the track will have a tendency to thump.

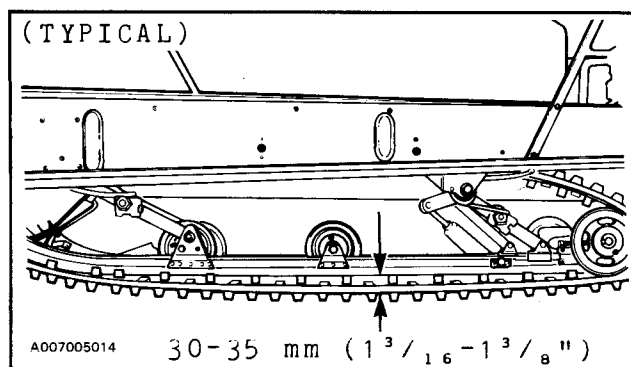

▼ **CAUTION:** Too much tension will result in power loss and excessive stresses on suspension components.

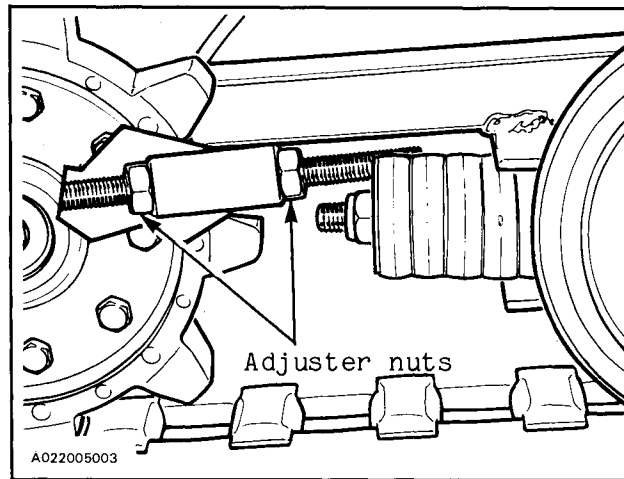

To adjust tension:

- loosen the adjuster nuts and then turn the other adjuster nuts to adjust. If correct tension is unattainable contact your dealer.

○ **NOTE:** Track tension and alignment are inter-related. Do not adjust one without the other.

ALIGNMENT

Start engine and allow track to rotate **slowly**. Check if track is well centered and turns evenly on the rear sprockets. The distance between track edges and slider shoe should be equal.

Misalignment can cause excessive wear of track edges and sprocket teeth.

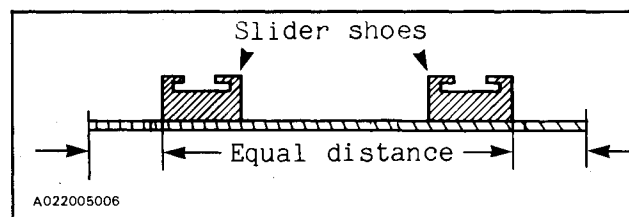
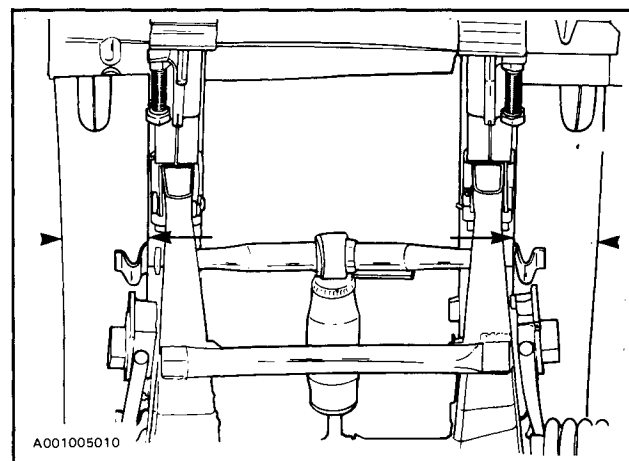

◆ **WARNING:** Before checking track alignment, ensure that the track is free of all particles which could be thrown out while track is rotating. Keep hands, tools, feet and clothing clear of track. Ensure no-one is standing in close proximity to the vehicle.

To correct, stop the engine, loosen adjuster nuts and tighten the track with adjuster nut on the side, where the slider shoe is the furthest to the edge of track.

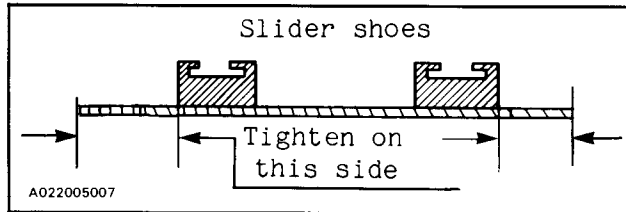

Tighten lock nuts and recheck the alignment.

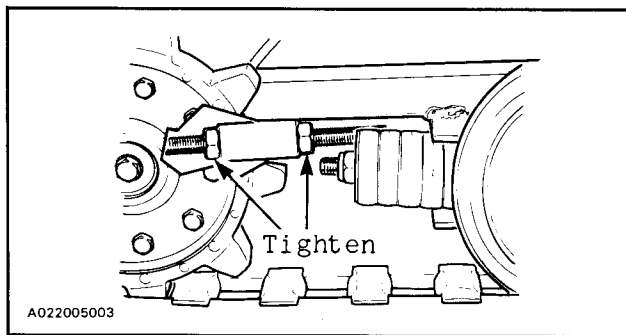

(NORDIK 60)

TENSION

Lift the rear of vehicle and support it off the ground. Using a ruler, check track tension.

▼ **CAUTION:** Too much tension will result in power loss and excessive stresses on suspension components.

○ **NOTE:** If the track tension is too loose, the track will have a tendency to thump.

The distance A between the top inside edge of the track and top of cross shaft at the second bogie wheel set from rear should be between 90-95 mm ($3\frac{1}{2}$ - $3\frac{3}{4}$ in).

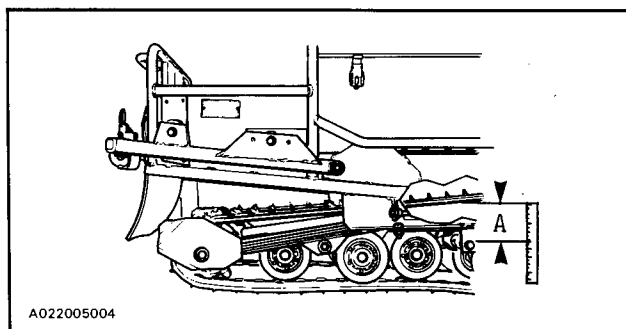

To adjust track use the following procedure:

- Loosen lock bolts and lock nuts.
- Turn adjuster bolts clockwise to tighten track, counterclockwise to loosen.

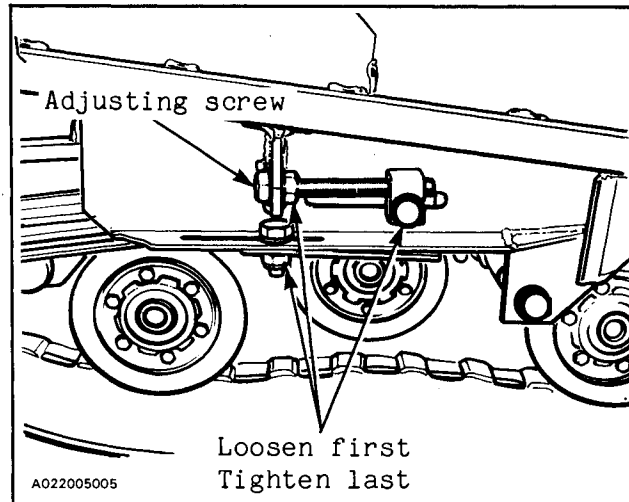

○ **NOTE:** Track tension and alignment are inter-related. Do not adjust one without checking the other.

ALIGNMENT

Start engine and allow track to rotate slowly. Check if track is well centered and turns evenly on the rear sprockets. The distance between track edges and link plates should be equal.

Misalignment can cause excessive wear of track edges and sprocket teeth.

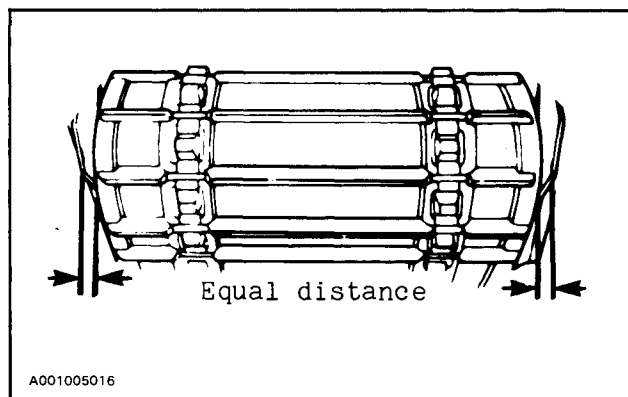

To correct:

Stop engine and on appropriate side, turn adjuster bolt clockwise to withdraw track from link plate.

Tighten lock bolts and nuts.

Restart engine and rotate track slowly and recheck alignment.

◆ **WARNING:** Before checking track alignment, ensure that the track is free of particles which could be thrown out while track is rotating. Keep hands, tools, feet and clothing clear of track. Ensure nobody is standing near the vehicle.

DRIVE CHAIN TENSION

Run vehicle forward so that true free-play can be taken. Check tension then turn driven pulley 1/2 turn counter-clockwise and recheck. Starting from maximum reading, adjust chain tension to obtain from 3 mm to 6 mm (1/8" to 1/4") free-play. Remove capscrew locking chain tensioner in place. (Tensioner is located at bottom left of gearbox.)

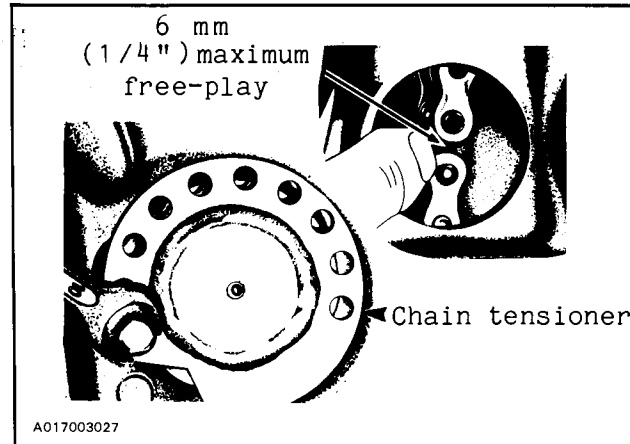

Rotate the tensioner as required to obtain correct chain tension.

Replace capscrew to lock chain tensioner in place.

IMPORTANT: The drive chain tension should be checked after the first 250 km of operation.

STEERING MECHANISM

Inspect the steering mechanism for tightness of components (steering arms, tie rods, ball joints, spring coupler bolts, etc.). If necessary, replace or retighten.

Torque steering arm bolts as shown:

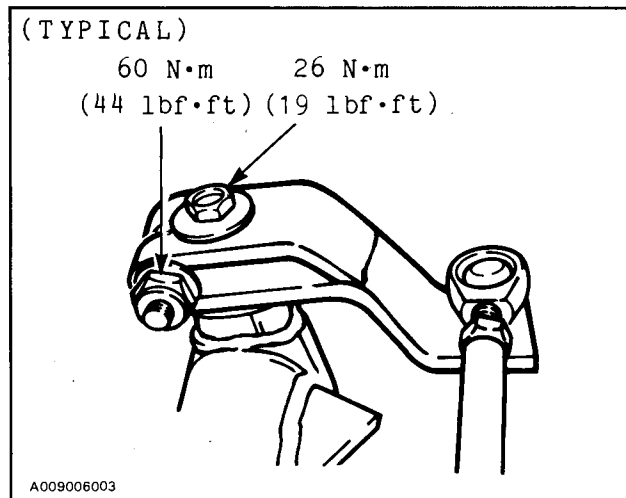



WARNING: Check the condition of the skis and the ski runners. Replace if more than half worn.

STEERING ADJUSTMENT

Skis should have a toe out of 3 mm (1/8"). To check, measure the distance between each ski at the front and rear of the leaf spring. The front distance should be 3 mm (1/8") more than the rear when the handlebar is horizontal.

IMPORTANT: Close the front of the skis manually to eliminate all slack from the steering mechanism.

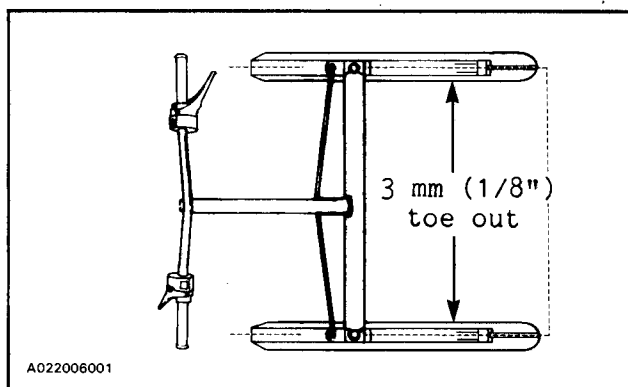

NOTE: Steering adjustment can be carried out by adjusting both tie rods. Adjustment is carried out, with handlebars horizontal, by turning the turn buckle that is on the same side as the misaligned ski.

If adjustment is required:

Loosen the lock nut(s) of the tie rod(s).

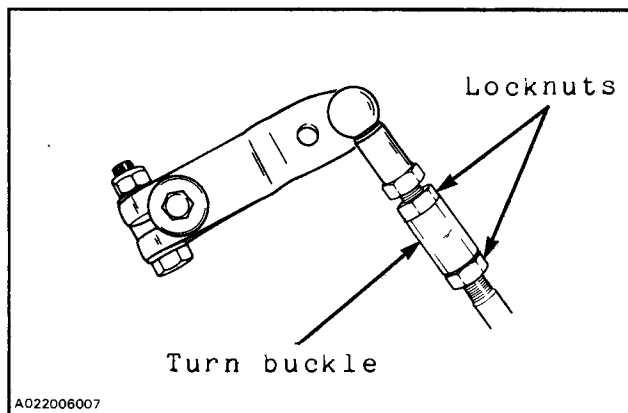

Turn the turn buckle(s) manually until ski(s) are properly aligned. Recheck the adjustment, if correct, tighten the lock nut(s).



WARNING: A minimum of 5 threads must be kept in the tie rod ends and in the turn buckles.

◆ **WARNING:** The ball joint socket must run parallel with the steering arm. The socket must be restrained when tightening the tie rod end lock nuts.

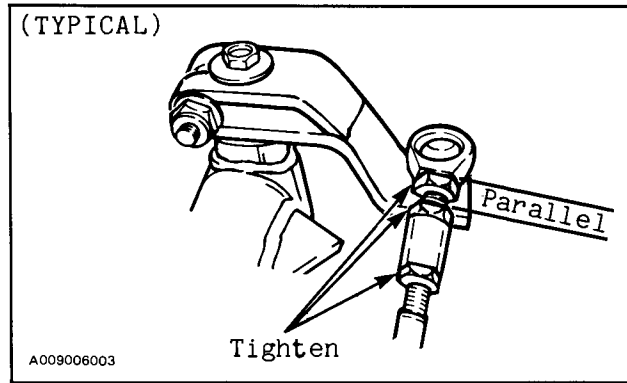

MUFFLER ATTACHMENT

The engine/exhaust system parts are vital toward efficient muffler function. Check all attachments. Replace the springs and/or tighten if necessary.

▼ **CAUTION:** Do not operate vehicle with muffler disconnected otherwise serious engine damage will occur.

ENGINE HEAD NUTS

With the engine cold, check that the engine head nuts are tight and equally torqued as follow:

Engine type	Torque N·m (lbf·ft)
447	25 (17)
503	22 (16)

Respect tightening sequence as follow:

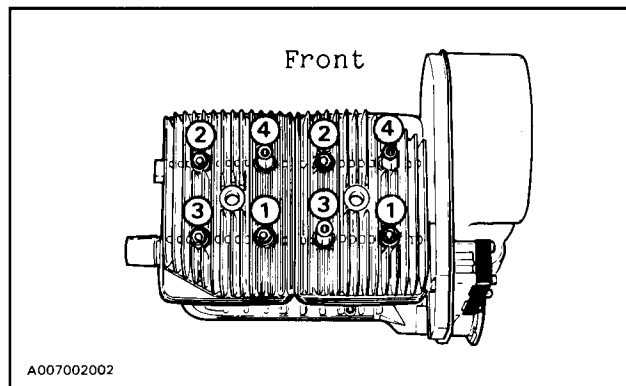

IMPORTANT: The engine head nut torque should be checked after the first 5 hours of operation.

ENGINE MOUNT NUTS

Check the engine mount nuts for tightness. Retighten if necessary.

CARBURETOR ADJUSTMENT

▼ CAUTION: Never operate your snowmobiles with the air intake silencer disconnected. Serious engine damage will occur if this notice is disregarded.

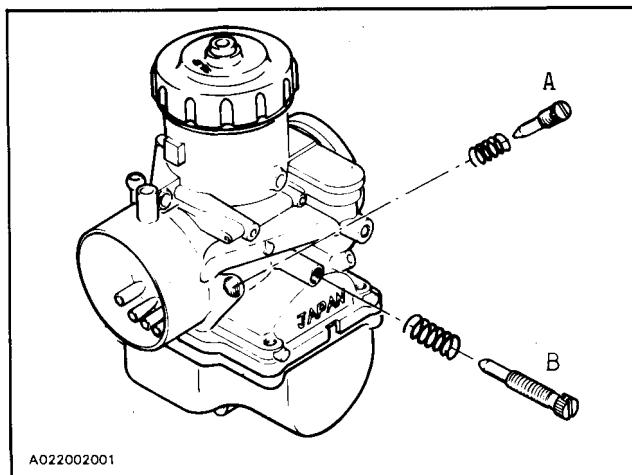

A) AIR SCREW ADJUSTMENT

Completely close the air screw (until a slight reseating resistance is felt) then back off screws follow:

ENGINE TYPE	AIR SCREW (A)	IDLE SPEED (B)
447	1.0 turn	1800-2000 R.P.M
503	1.5 turn	1800-2000 R.P.M.

B) IDLE SPEED ADJUSTMENT

Turn the idle speed screw clockwise until it contacts the throttle slide then continue turning two (2) additional turns. This will provide a preliminary idle speed setting. Start the engine and allow it to warm then adjust the idle speed by turning the idle speed screw clockwise or counter-clockwise. Idle speeds are mentioned above.

▼ **CAUTION:** Do not attempt to set the idle speed by using the air screw. Severe engine damage can occur. If idle speed is unattainable contact the dealer.

FUEL FILTER

The fuel filter is installed in the end of fuel inlet hose, inside the fuel tank.

The fuel filter should be replaced once a year.

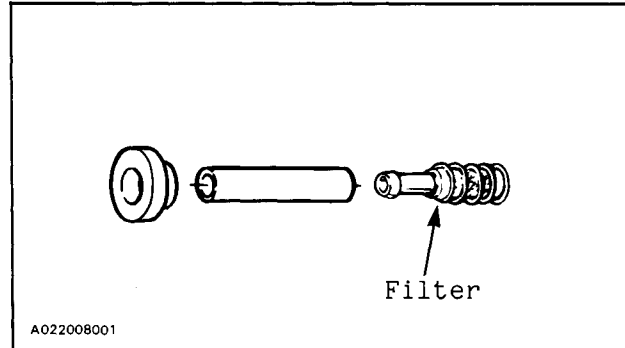

FAN BELT

Inspect belt for cracks, uneven wear, etc. Check fan belt tension, 10 mm (3/8") deflection should exist when deflection is correct.

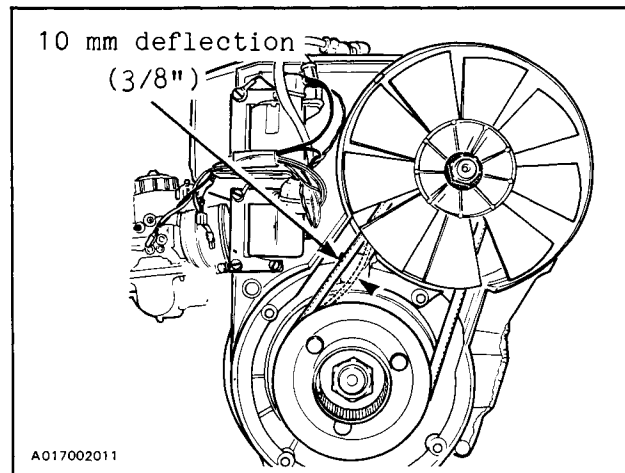

If belt seems damaged or if tension is incorrect, contact your dealer immediately.

◆ **WARNING:** If fan protector is removed, always reinstall after servicing.

HEADLAMP BEAM AIMING

The angle of the headlamp beam has been pre-adjusted prior to delivery. Should you wish re-adjustment, place the vehicle on a flat surface 7.6 m (25') from a wall or screen.

With the suspension correctly adjusted, the rider seated on the vehicle and the high beam ON check that the center of high intensity zone of high beam is 50 mm (2") below horizontal line of headlamp height.

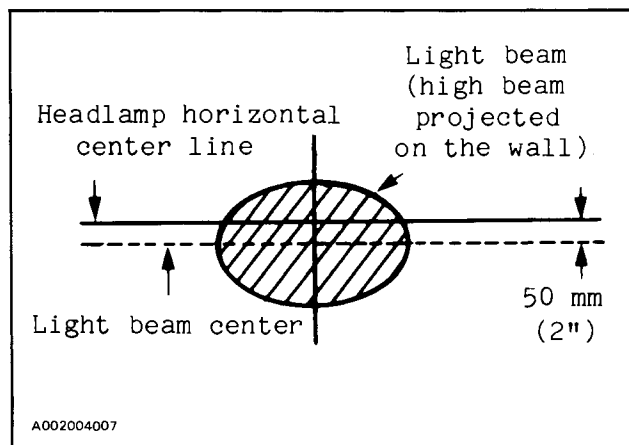
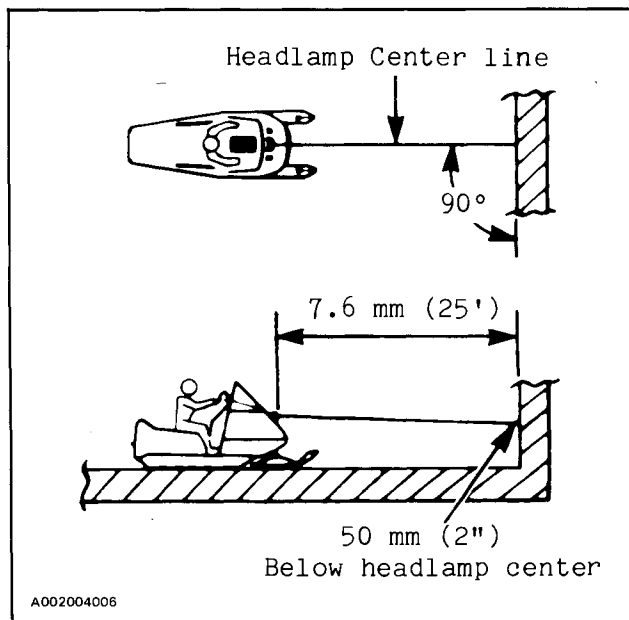

To adjust, remove the four caps, turn upper or lower adjusting screws to obtain desired beam position.

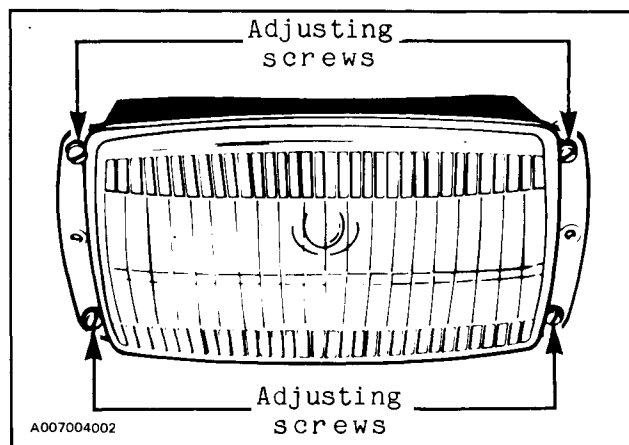

BULB REPLACEMENT

If the headlamp bulb is burnt, tilt hood, unplug the connector from the headlamp. Remove the rubber boot and unfasten bulb retainer clips. Detach the bulb and replace.

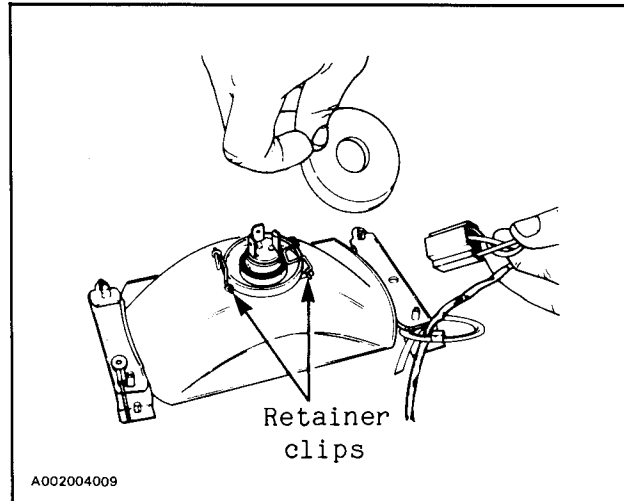

If taillight bulb is burnt, expose the bulb by removing the red plastic lens. To remove, unfasten the two (2) screws.

◆ **WARNING:** Always check light operation after bulb replacement.

GENERAL INSPECTION

Check the electrical wiring and components, retighten loose connections. Check for stripped wires or damaged insulation. Thoroughly inspect the vehicle and tighten loose bolts, nuts and linkage.

◆ **WARNING:** Inspect skis and ski runners for wear. Replace as required.

STORAGE

It is during summer, or when a vehicle is not in use for any length of time, that proper storage is a necessity. Storage of the snowmobile during long period of inactivity consists of checking and replacing missing, broken or worn parts; proper lubrication and treatment to insure that parts do not become rusted, cleaning items such as carburetor of oil mixtures, to prevent gum varnish formation within the carburetor, and in general, preparing the vehicle so that when the time comes to use the snowmobile again it will be in top condition.

◆ **WARNING:** Only perform such procedures as detailed in this manual. It is recommended that dealer assistance be periodically obtained on other components/systems not covered in this manual. Unless otherwise specified, engine should be turned OFF for all lubrication and maintenance procedures.

TRACK

Inspect track for wear, cuts, missing tracks inserts or broken rods.

Make any necessary replacement.

◆ **WARNING:** Do not operate a snowmobile with a cut, torn or damage track.

Lift rear of vehicle until track is clear of ground, then support it with a brace or trestle. The snowmobile should be stored in such a way that the track does not stay in contact with cement floor or bare ground.

○ **NOTE:** The track should be rotated periodically (every 40 days). Do not release track tension.

▼ **CAUTION:** To prevent track damage, temperature in the storage area must not exceed 38°C (100°F).

SUSPENSION

(NORDIK 50)

Remove any dirt or rust. Grease all components equipped with grease fittings. Wipe off surplus. Replace worn slider shoes.

(NORDIK 60)

Remove the bogie wheel sets from the vehicle. Remove cross shaft from bogie wheel set. Clean bogie wheel assembly and cross shaft of dirt or rust.

Check condition of shaft and replace if bent or worn. Apply a coat of low temp. grease on cross shaft.

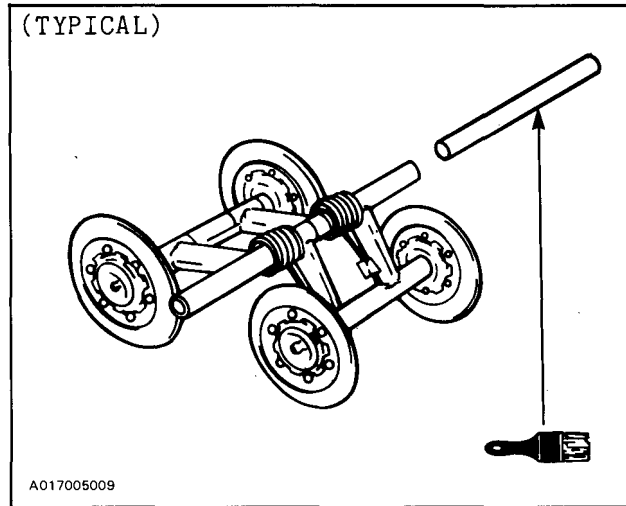

Spray bogie wheel springs with metal protector. If unavailable, wipe with a cloth or rag soaked in oil.

Reassemble entire bogie wheel set, making sure assembly moves freely. Reinstall bogie wheel set in the proper position.

Torque cross shaft bolts to 30 N·m (23 lbf·ft). Repeat above steps on remaining bogie wheel sets.

SKIS

Wash or brush all dirt or rust accumulation from the skis and springs. Grease the ski legs at the grease fittings. Check the condition of the skis, ski runners and leaf spring. Replace if weak or worn more than half.

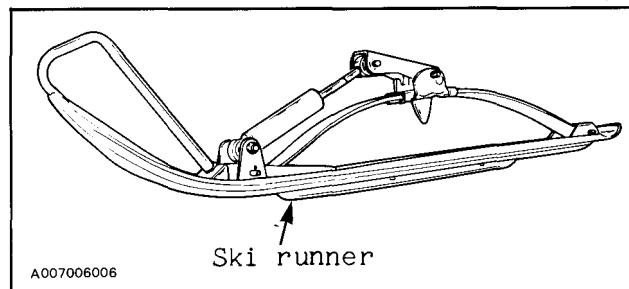

CONTROLS

Lubricate the steering mechanism. Inspect all components for tightness, (spring coupler bolts, steering arm locking bolts, tie rods, ball joints, etc.). Tighten if necessary. Oil metal moving joints of the brake mechanism.

◆ **WARNING:** Do not lubricate the throttle and/or brake cables and housings. Avoid getting oil on the brake pads.

Coat all electrical connections and switches with a greaseless metal protector. If unavailable, use petroleum jelly.

GEARBOX

Drain gearbox and refill with 450 mL (16 oz) of fresh Bombardier chaincase oil.

○ **NOTE:** Drain plug is accessible through a hole located underneath vehicle.

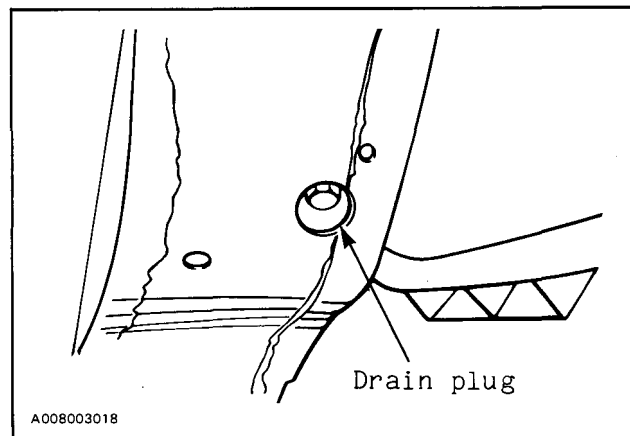

DRIVE PULLEY

Inspection and cleaning must be performed by the dealer at the end of each season.

DRIVEN PULLEY

Remove drive belt.

Spray internal pulley surfaces with metal protector.

○ **NOTE:** Leave drive belt off during entire storage period.

ENGINE AND PRIMER LUBRICATION

Engine internal parts must be lubricated to protect cylinder walls from possible rust formation during the storage period.

To perform the storage procedures (engine and primer valve) proceed as follows:

ENGINE

1. Start the engine and allow it to run at idle speed until the engine reaches its operational temperature.
2. Stop the engine, remove the air silencer box, start the engine.
3. Using "Bombardier Snowmobile Injection Oil", squirt oil into the carburetor throat until the engine dies.
4. Remove the spark plugs and pour approximately 85 ml (3 imp. oz.) of oil into the cylinders.
5. Crank the engine to allow the crankshaft to turn 2 or 3 revolutions.
6. Reinstall the spark plugs and the air intake silencer.

Do not run engine during storage period.

PRIMER VALVE

1. Disconnect the inlet primer hose from the primer valve.

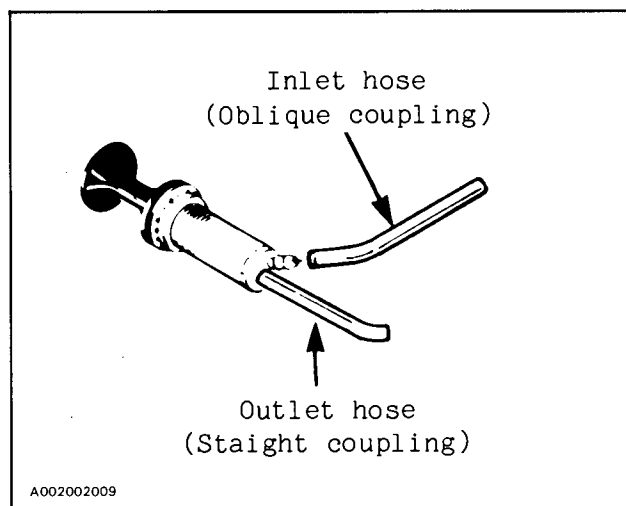

2. Hold the hose higher than the gas tank to prevent gasoline from draining.
3. Using an appropriate hose, connect one end of the hose to the inlet of the primer valve and place the other end in a Bombardier Snowmobile Injection Oil container.
4. Activate the primer in order to fill it with oil.
5. Reinstall the inlet primer hose to the primer valve.

FUEL TANK AND CARBURETOR

Remove the cap then using a syphon, remove the gasoline from tank.

◆ **WARNING:** Gasoline is flammable and explosive under certain conditions. Always manipulate in a well ventilated area. Do not smoke or allow open flames or sparks in the vicinity.

Carburetor must be dried out completely to prevent gum formation during the storage period.

Once the fuel tank is emptied, remove the float chamber drain plug from carburetor. Drain carburetor and reinstall plug.

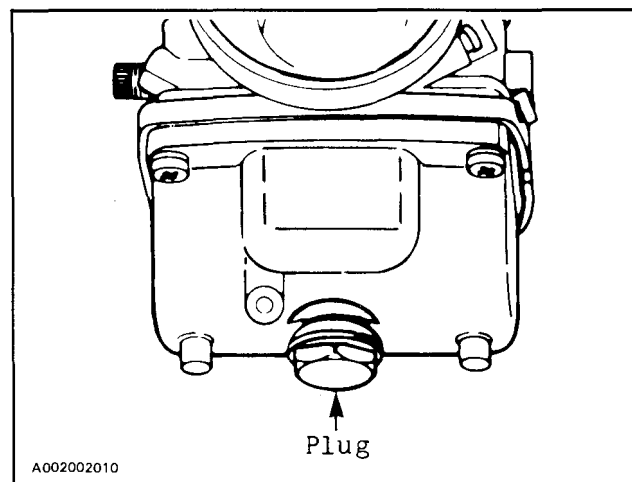

Check all fuel lines. Replace if necessary.

CHASSIS

Clean the vehicle thoroughly, removing all dirt and grease accumulation.

▼ **CAUTION:** Plastic alloy components such as fuel tank, controls, windshield, etc., can be cleaned using mild detergents or isopropyl alcohol. Do not use strong soaps, degreasing solvents, abrasive cleaners, paint thinners, etc. Do not apply isopropyl alcohol directly on decals.

Clean the frame. For the aluminium portion use only "Aluminum cleaner" and follow instructions on the container.

Touch up all metal spots where paint has been scratched off. Spray all bare metal parts with metal protector. Wax the cab for better protection.

▼ **CAUTION:** Cover the snowmobile with an opaque tarpaulin. This will prevent the sun rays or grime from affecting the plastic components and vehicle finish.

GENERAL INSPECTION

Check the electrical wiring and components, retighten loose connections. Check for stripped wires or damaged insulation.

Thoroughly inspect the vehicle and tighten loose bolts, nuts and linkage.

○ **NOTE:** Leave the drive belt off the pulleys for the entire storage period.

PRE-SEASON PREPARATION

To simplify the pre-season preparation we have drawn up a small chart. The chart indicates servicing points to be performed by you and your servicing dealer. If these services are performed as suggested, your vehicle will give you many hours of fun and low cost use.

IMPORTANT: Observe all Warnings and Cautions mentioned throughout this manual which are pertinent to the item being checked. When component conditions seem less than satisfactory, replace with genuine Bombardier parts or suitable equivalents.

	TO BE PERFORMED BY DEALER	
PRE-SEASON PREPARATION CHART		d
	TO BE PERFORMED BY OWNER	o
Change spark plugs*		o
Check chaincase oil level		o
Replace fuel filter (located inside fuel tank)		o
Check track tension and alignment		o
Lubricate suspension		o
Inspect drive belt and install		o
Check throttle cable for damage and free operation		o
Check steering alignment and ski runner condition		o
Inspect seals for possible cuts or leaks		o
Check electrical wiring (broken wire, damaged insulation)		o
Inspect condition of starting rope		o
Check tightness of all bolts, nuts and linkage		o
Refill gas tank		o
Inspect brake condition and operation		d
Set engine timing		d
Check pulleys, verify components and clean. Lubricate.		d
Adjust carburetor		d
Check fan belt condition and adjust tension		d

 **NOTE:** Before installing new spark plugs, it is suggested to burn the excess storage oil by starting the engine, using the old spark plugs.

 **CAUTION:** Only perform this procedure in a well ventilated area.

TROUBLE SHOOTING GUIDE

○ **NOTE:** The possible causes have been listed in an order of frequency. Therefore, items should be checked out in the same order as mentioned in the trouble shooting guide.

SYMPTOMS	POSSIBLE CAUSES	WHAT TO DO
Engine turns over but fails to start or starts with difficulty	1. No fuel to the engine	Check the tank level. Check for possible clogging of fuel line, item 4.
	2. Flooded engine	Remove wet spark plugs, turn ignition to off and crank engine several times. Install clean dry spark plugs. Start engine following usual starting procedure. If engine continues to flood see your dealer. If trouble persists, contact your dealer.
	3. Spark plug/ignition	Check for fouled or defective spark plug. Disconnect spark plug wire, unscrew plug and remove from cylinder head. Reconnect wire and ground exposed plug on engine cowl, being careful to hold away from spark plug hole. Follow engine starting procedure and check for spark. If no sparks appear, replace, spark plug. If trouble persists, contact your dealer.
	4. Clogged fuel line (water or dirt)	Remove and clean the fuel filter. Change filter if necessary. Check fuel line and fuel line fittings. Check the cleanliness of fuel tank.

TROUBLE SHOOTING GUIDE (Con't...)

SYMPTOMS	POSSIBLE CAUSES	WHAT TO DO
Engine turns over but fails to start or starts with difficulty	5. Carburetor	Contact your dealer for repair.
	6. Too much oil in fuel	Contact your dealer.
	7. Engine timing	Engine timing may be incorrect or out of adjustment. Contact your dealer.
	8. Engine compression	Running with a lean fuel mixture may produce excessive engine wear resulting in poor engine compression. If this occurs, contact your dealer at once.
Engine will not turn manually	1. Seized engine	In the case of a seized engine contact your dealer.

SYMPTOMS	POSSIBLE CAUSES	WHAT TO DO
Engine lacks acceleration or power.	1. Fouled or defective spark plug	Check item 3 of "Engine turns over but fails to start or starts with difficulty."
	2. Clogged fuel line (water or dirt)	Check fuel line condition. (See item 4 of "Engine turns over but fails to start or starts with difficulty").
	3. Carburetors	Contact your dealer.
	4. Ignition	First check item 3 of "Engine turns over but fails to start or starts with difficulty". If the ignition system still seems faulty, contact your dealer.
	5. Engine	If unable to locate specific symptoms, contact your dealer.
Engine continually backfires	1. Faulty spark plug	Check item 3 of "Engine turns over but fails to start or starts with difficulty."
	2. Overheating	Carburetor set too lean. Contact your dealer.
	3. Engine timing incorrectly set	Contact your dealer.

(Con't...)

SYMPTOMS	POSSIBLE CAUSES	WHAT TO DO
Snowmobile cannot reach full speed	1. Drive belt	Check for damaged or worn drive belt. Replace if necessary.
	2. Incorrect track adjustment	Check track tension and alignment. Readjust to specifications. (See Maintenance Section).
	3. Engine	Check item 1 of 5 of "Engine lacks acceleration or power."
	4. Pulley misaligned	Contact your dealer.

TOOLS

As standard equipment, each new snowmobile is supplied with a basic tool kit such as screwdriver, wrenches, emergency starter rope, etc.

STANDARD TOOLS

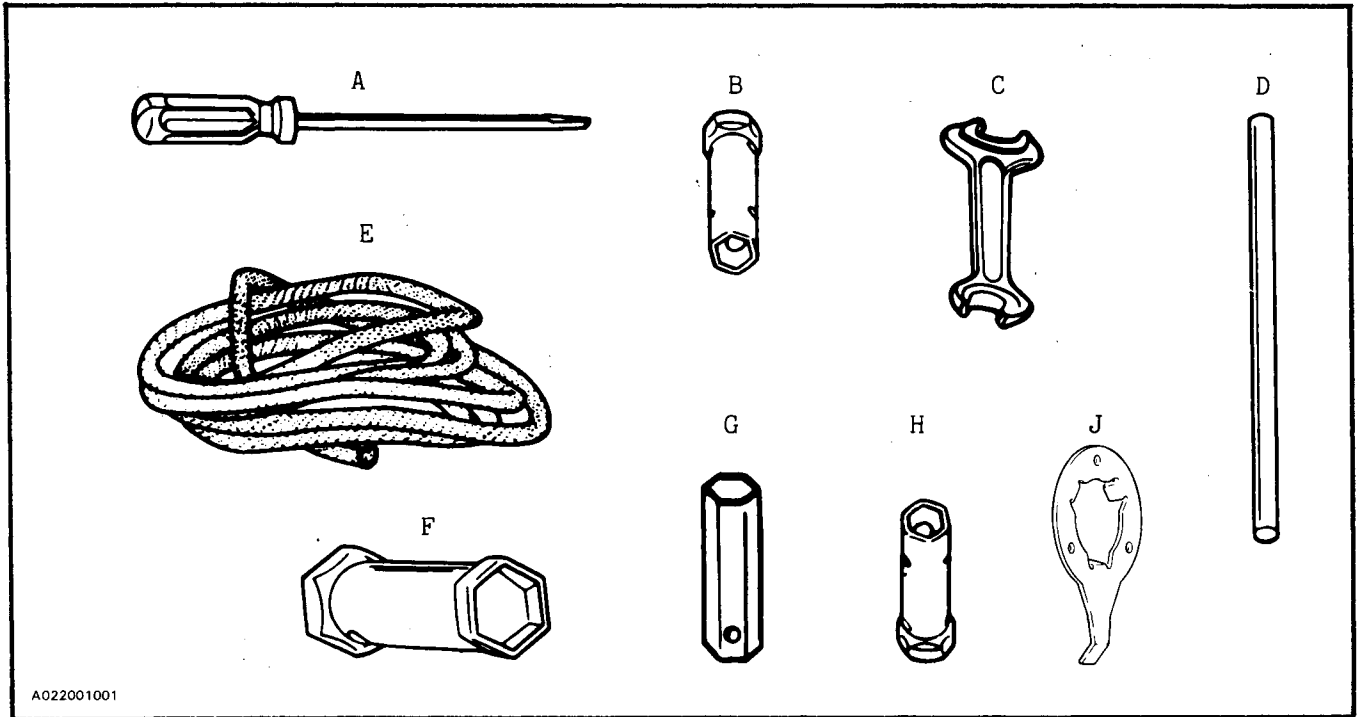

- A. Screwdriver
- B. Socket 10/13 mm
- C. Open end wrench 10/13 mm
- D. Socket wrench handle
- E. Starter rope
- F. Socket 21/26 mm
- G. Extension bar
- H. Socket 11/13 mm
- J. Fan wrench

SPECIFICATIONS

	NORDIK 50	NORDIK 60
ENGINE		
Type	447	503
No of cylinder	2	2
Bore	67.5 mm (2.657")	72 mm (2.834")
Stroke	61 mm (2.401")	61 mm (2.401")
Displacement	436.6 cm ³ (26.64 in ³)	496.7 cm ³ (30.31 in. ³)
Compression ratio (corrected)	6.3:1	6.3:1
Maximum R.P.M.	7250 R.P.M.	5750 R.P.M.
Carburetor type	VM 32-310	VM 32-259B
Carburetor adjustment:		
- air screw	1.0 turn	1 ½ turn
- idle speed	1800-2000 R.P.M.	1800-2000 R.P.M.
Torque:		
- engine head nuts	23 N·m (17 lbf·ft)	M8: 22 N·m (16 lbf·ft)
- crankcase nuts	M6: 9 N·m (7 lbf·ft) M8: 21 N·m (15 lbf·ft)	M8: 22 N·m (16 lbf·ft)
- magneto ring nut	85 N·m (63 lbf·ft)	85 N·m (63 lbf·ft)
- fan nut	65 N·m (48 lbf·ft)	65 N·m (48 lbf·ft)
- crankcase engine support nuts	38 N·m (28 lbf·ft)	38 N·m (28 lbf·ft)
- exhaust manifold bolts	21 N·m (15 lbf·ft)	21 N·m (15 lbf·ft)
CHASSIS		
Overhall length	294 cm (115.7")	300 cm (118")
Overhall width	99 cm (39")	99 cm (39")
Overhall height	129 cm (50.8")	129 cm (50.4")
Ski stance (center to center)	82 cm (32.3")	82 cm (32.3")
Ski alignment (toe out)	3.0 mm (1/8")	3.0 mm (1/8")
Torque:		
- steering arm/ski leg bolt	60 N·m (45 lbf·ft)	60 N·m (45 lbf·ft)
- steering column/handlebar	26 N·m (19 lbf·ft)	26 N·m (19 lbf·ft)
Dry weight	223 kg (491 lbs)	265 kg (583 lbs)
Bearing area	10268 cm ² (1,592 in ²)	12054.8 cm ² (1,869 in ²)
Ground pressure	2,17 kPa (0.315 lb/in ²)	2,19 kPa (0.317 lb/in ²)
POWER TRAIN		
Track:		
- width	50 cm (19.7")	60 cm (23.6")
- length	370 cm (145.7")	370 cm (145.7")
- tension	30-35 mm (1 3/16"-1 3/8") gap between slider shoe and the bottom inside of track.	A deflection of 90-95 mm (3 1/2-3 3/4 in) should exist between the top inside edge of the track and the top of the cross shaft of the se- cond bogie wheel set from the rear of the vehicle.
- alignment	Equal distance between edges of track and link plates	

SPECIFICATIONS

	NORDIK 50	NORDIK 60
Standard gear ratio	17/34	17/40
Gearbox chain tension	3 to 6 mm (1/8" to 1/4")	3 to 6 mm (1/8" to 1/4")
Drive belt:		
- number	414 6175 00	414 6175 00
- max. width	33.3 mm (1 5/16")	33.3 mm (1 5/16")
- min. width	30.1 mm (1 3/16")	30.1 mm (1 3/16")
Chaincase/gearbox oil capacity	450 ml (16 oz.)	450 ml (16 oz.)
ELECTRICAL		
Lighting system (output)	160 watts	160 watts
Bulb:		
- headlamp	H4 60/55 W	H4 60/55 W
- tail/stop	5/21 W	5/21 W
- speedometer	5 W	5 W
Spark plug:		
- type	NGK BR9ES	NGK BR8ES
- gap	0.4 mm (.016")	0.4 mm (.016")
Ignition timing:		
- timing mark (B.T.D.C.)	1.88 mm (.074") (18°)	2.29 mm (.090") (20°)
- stroboscopic timing	6000 RPM	6000 RPM
FUEL		
Gas type		Regular leaded or unleaded
Fuel tank capacity		
-SI		22.7 liters
-imp.		5 gallons
-U.S.		6 gallons
Preximed fuel/oil		
- type		Blizzard oil
- ratio		50:1
BRAKE		
Type		Disk self-adjusting
Lining minimum thickness		when only 1 mm (1/32") of fixed pad is projected out of caliper.
Control lever adjustment	13 mm (1/2")	minimum distance from handlebar grip when fully applied.

Bombardier Inc. reserves the right to make changes in design and specifications and/or to make additions to, or improvements in its product without imposing any obligation upon itself to install them on its products previously manufactured.

CAUTION: Wiring diagram letter code is printed at the end of each wires in the vehicle section. Color code applies to engine section only.

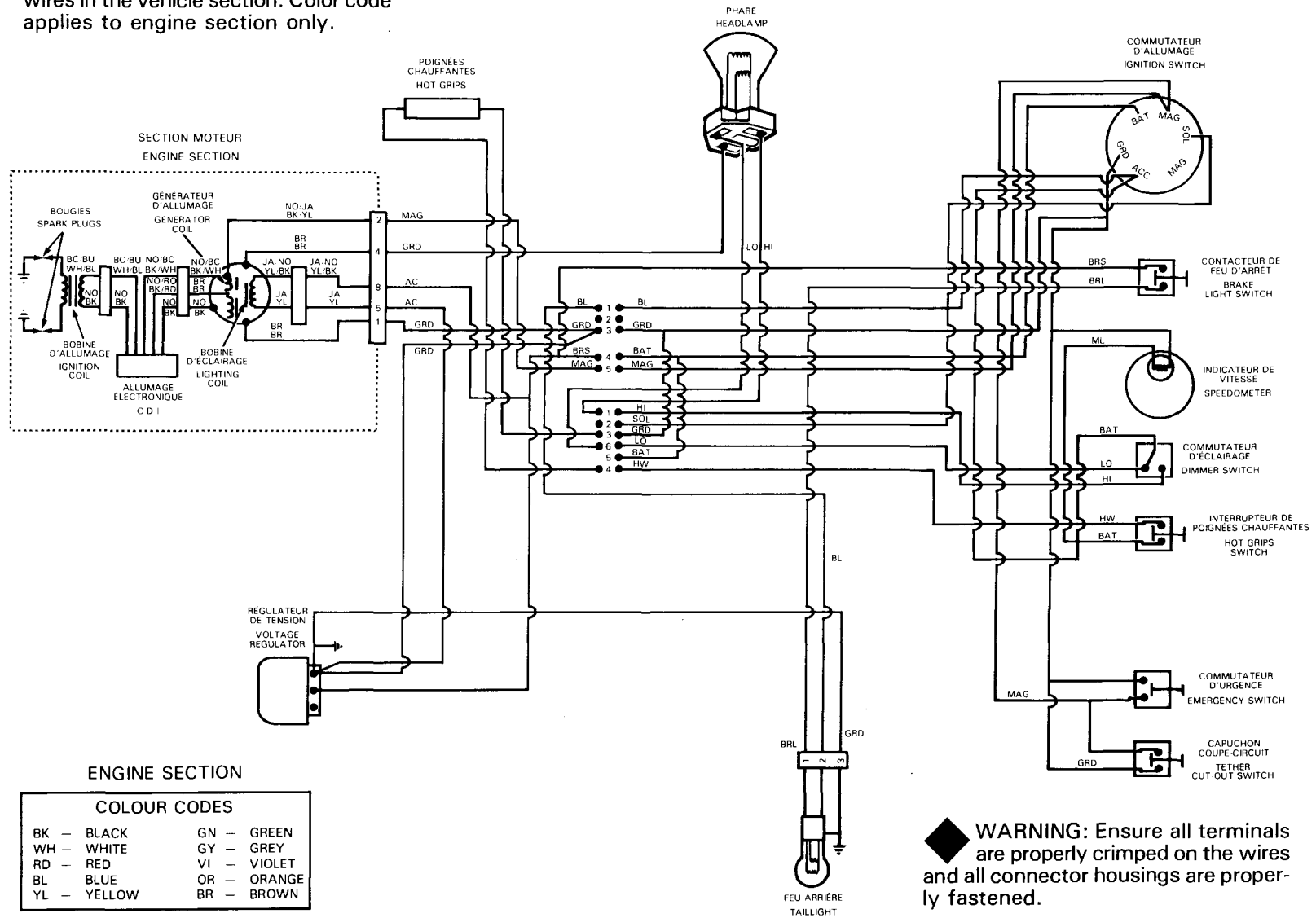

ENGINE SECTION

COLOUR CODES	
BK - BLACK	GN - GREEN
WH - WHITE	GY - GREY
RD - RED	VI - VIOLET
BL - BLUE	OR - ORANGE
YL - YELLOW	BR - BROWN

WARNING: Ensure all terminals are properly crimped on the wires and all connector housings are properly fastened.

SI* METRIC INFORMATION GUIDE

BASE UNITS			
DESCRIPTION	UNIT	SYMBOL	
length	meter	m	
mass	kilogram	kg	
force	Newton	N	
liquid	liter	l	
temperature	Celsius	°C	
pressure	kilopascal	kPa	
torque	Newton meter	N•m	
speed	kilometer per hour	km/h	

PREFIXES			
PREFIX	SYMBOL	MEANING	VALUE
kilo	k	one thousand	1000
centi	c	one hundredth of	0.01
milli	m	one thousandth of	0.001

CONVERSION FACTORS			
TO CONVERT	TO †	MULTIPLY BY	
lbf•ft	lbf•in	12	
imp. oz	U.S. oz	0.96	
imp. gal.	U.S. gal.	1.2	
in	mm	25.4	
in	cm	2.54	
ft	m	0.3	
MPH	km/h	1.61	
in ²	cm ²	6.45	
in ³	cm ³	16.39	
imp. oz	ml	28.41	
U.S. oz	ml	29.57	
imp. gal.	l	4.55	
U.S. gal.	l	3.79	
oz	g	28.35	
lb	kg	0.45	
lbf	N	4.4	
lbf•in	N•m	0.11	
lbf•ft	N•m	1.36	
PSI	kPa	6.89	
Fahrenheit	Celsius	$(^{\circ}\text{F} - 32) \div 5/9$	
Celsius	Fahrenheit	$(^{\circ}\text{C} \times 1.8) + 32$	

*The international system of units abbreviates "SI" in all languages.

†To obtain the inverse sequence, divide by the given factor. To convert "mm" to "in", divide by 25.4.

CHANGE OF ADDRESS OR OWNERSHIP

Any change in address or ownership should be brought to the attention of the manufacturer by completing and sending out the card supplied below.

NOTICE TO ALL NEW OWNERS: Make sure to receive the warranty registration card from the previous owner, at the time the ownership is transferred. Also enclose a photocopy of this registration card when informing of a change of ownership.

CHANGE OF ADDRESS

VEHICLE IDENTIFICATION NUMBER

--	--	--	--	--	--	--	--	--	--	--	--	--	--	--	--	--	--	--	--

OLD ADDRESS:

NAME

NO STREET APT.

CITY STATE/PROVINCE ZIP/POSTAL CODE

NEW ADDRESS:

NAME

NO STREET APT.

CITY STATE/PROVINCE ZIP/POSTAL CODE



CHANGE OF OWNERSHIP

VEHICLE IDENTIFICATION NUMBER

--	--	--	--	--	--	--	--	--	--	--	--	--	--	--	--	--	--	--	--

The ownership of this vehicle is transferred

FROM:

NAME

NO STREET APT.

CITY STATE/PROVINCE ZIP/POSTAL CODE

TO:

NAME

NO STREET APT.

CITY STATE/PROVINCE ZIP/POSTAL CODE



STAMP

BOMBARDIER INC.
ATT.: WARRANTY DEPARTMENT
VALCOURT, QUEBEC
CANADA, JOE 2L0

STAMP

BOMBARDIER INC.
ATT.: WARRANTY DEPARTMENT
VALCOURT, QUÉBEC
CANADA, JOE 2L0

