



YAMAHA

SNOWMOBILE

ET340ED

SUPPLEMENTARY SERVICE MANUAL



[Frame serial number: 8J9-040101 ~ 8J9-049999
Engine serial number: E338-040101 ~ E338-049999]

CONTENTS

1.	NEW SERVICE PROCEDURE.....	1
2.	MAINTENANCE INTERVALS.....	2
3.	SPECIFICATIONS.....	4
4.	SPECIAL TOOLS.....	10
5.	WIRING DIAGRAM.....	11
6.	WIRE AND PIPE ROUTING DIAGRAM.....	12

1. NEW SERVICE PROCEDURE

(New service procedure applied to the 1980 ET340ED)

Carburetor

1. To achieve the precise fitting of the main nozzle, the main nozzle is press-fitted to the mixing chamber body, and accordingly the main nozzle cannot be removed.

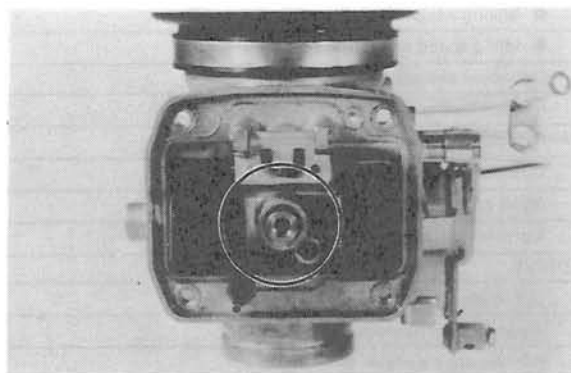

2. For better performance, the recommended type of the main jet which is more effective at altitudes is changed.

[Main jet setting chart]

Altitude \ Temperature	-30°C (-22°F)	-20°C (-4°F)	-10°C (14°F)	0°C (32°F)	10°C (50°F)	20°C (68°F)
Sea level	← #250 →		#240 (Std)	← #220 →		
~ 600m (2000 ft)	← #240 (Std) →		← #220 →			
~ 1200m (4000 ft)	← #240 (Std) →	#220		← #210* →		
~ 1800m (6000 ft)	← #220 →		#210*		← #200* →	
~ 2400m (8000 ft)	← #210 →		← #200 →			← #190 →
~ 3000m (10000 ft) or more	← #200 →		← #190 →			

* Newly changed specification.

2. MAINTENANCE INTERVALS

[PERIODIC MAINTENANCE]

Check point	Every			When necessary	Seasonally
	20 hrs. or 400 km (250 mi)	40 hrs. or 800 km (500 mi)	80 hrs or 1600 km (1000 mi)		
ENGINE:					
Tightness of bolts and nuts	○				○
Bends, cracks and wear	○				○
Abnormal noise	○				○
Loose connection and breaks of fuel and pulse pipes	○				○
Loose connection and breaks of oil pipes	○				○
Loose connection and breaks of oil delivery pipe	○				○
Manual rope starter system		○			○
Carburetor					
● Operation of starter jet		○			○
● Mixing adjuster (pilot screw)				○	○
● Idling speed adjustment				○	○
Operation and adjustment of oil pump		○			○
Ignition timing					○
Cylinder compressions			○		○
Cylinder head/exhaust pipe decarbonize					○
Spark plug condition, gap and cleaning	○				○
Tightening of the cylinder head**					○
DRIVE:					
Tightness of bolts and nuts	○				○
Wear on slide runners	○				○
Primary drive system		○			○
V-belt	○				○
Secondary drive system		○			○
Sheave distance		○			○
Sheave offset		○			○
Brake pad wear		○			○
Brake operation and adjustment		○			○
Guide wheel rubber		○			○
Wear of drive track wheel sprocket		○			○
Drive track adjustment		○			○
Breaks in drive track		○			○
Bends in front and rear axles		○			○
Checking of lock washers		○			○
Drive chain adjustment		○			○
Drive chain oil level		○			○
BODY:					
Tightness of bolts and nuts	○				○
Bends and cracks	○				○
Welded riveted, joints	○				○
Ski adjustment		○			○
Ski runner wear	○				○
Breaks in fuel tank		○			○
Cleaning of fuel tank					○
Fuel filter					○
Loose connection and breaks in fuel pipe		○			○
Breaks in oil tank		○			○
Oil filter					○

Check point	Every			When necessary	Seasonally
	20 hrs. or 400 km (250 mi)	40 hrs. or 800 km (500 mi)	80 hrs or 1600 km (1000 mi)		
ELECTRICAL:					
Wear, breakage of wire covering		○			○
Breaks in high-tension cord	○				○
Voltage regulator working voltage					○
Operation of engine stop switch		○			○
Operation of tether switch		○			○
Headlight		○			○
Taillight		○			○
Brake light		○			○
Battery fluid top up/specific gravity and breather pipe	○				○

** Retighten every 10 hours from the first use.

[LUBRICATION INTERVALS]

Lubrication point	Every			When necessary	Seasonally	Oil/Grease Brand name
	20 hrs. or 400 km (250 mi)	40 hrs. or 800 km (500 mi)	80 hrs or 1600 km (1000 mi)			
ENGINE						
Starter case					○	Aeroshell grease #7A or Esso Beacon 325 grease
Oil pump control box			○		○	
Pump drive cover			○		○	
Oil in the oil tank				○		YAMALUBE 2-cycle oil
DRIVE						
Primary sheave weight and roller pins		○			○	Molybdenum disulfide snowmobile grease
Secondary shaft and sliding sheave		○			○	Molybdenum disulfide snowmobile grease
Front axle housing		○			○	Light all-purpose grease
Shaft 1 and shaft 2 (Slide rail)			○		○	
Drive chain oil replacement		○			○	Gear oil API "GL-3" SAE #75 or #80
BODY						
Steering column lower bearing		○			○	Light all-purpose grease
Steering column upper bearing		○			○	Motor oil
Steering links		○			○	Light all-purpose grease
Ski column		○			○	
Ski wear plate		○			○	
Ski retaining pin		○			○	
Brake wire end stopper and brake lever		○			○	Esso Beacon 325 grease

3. SPECIFICATIONS

NOTE: * New specification
(Compared with 1979 ET340EC)

General

Model	ET340ED
Model: Model (I.B.M. No.) Frame I.D. & starting number Engine I.D. & starting number	* ET340ED (8J9) * 8J9-040101 * E338-040101
Dimension: Overall length Overall width (std) Overall height (w/windshield)	* 2,555 mm (100.6 in) 970 mm (38.2 in) 1,040 mm (40.9 in)

Engine

Description: Engine type Engine model Displacement Bore × Stroke Effective compression ratio Starting system Ignition system Lubrication system	Fan cooled two-stroke 5-port, twin cylinders E338 338 cc (20.6 cu.in) 60 × 59.6 mm (2.36 × 2.35 in) 6.5 : 1 Recoil hand starter and electric starter C.D.I. "Autolube" oil inspection
Cylinder head: Combustion chamber volume (with spark plug) Compression chamber type Head gasket thickness	21.3 cc (1.30 cu.in) Dome + Squish 0.5 mm (0.02 in)
Cylinder: Material Bore size Taper limit Out of round limit	Cast iron sleeves aluminum 60 mm (2.362 in) 0.05 mm (0.0020 in) 0.01 mm (0.0004 in)
Piston: Piston skirt clearance (Measuring point) Piston oversize Piston pin outside diameter × length	0.040 ~ 0.045 mm (0.0016 ~ 0.0018 in) (10 mm from piston skirt end) 1st 60.25 mm (2.372 in) 2nd 60.50 mm (2.382 in) 3rd 60.75 mm (2.392 in) 4th 61.00 mm (2.402 in) φ16 × 47 mm (φ0.630 × 1.85 in)
Piston ring: Piston ring design (Top) Piston ring design (2nd) Ring end gap (installed) (Top) Ring end gap (installed) (2nd)	Keystone Keystone 0.35 ~ 0.55 mm (0.014 ~ 0.022 in) 0.35 ~ 0.55 mm (0.014 ~ 0.022 in)
Small end bearing: Type	Needle bearing
Big end bearing: Type	Needle bearing
Crankshaft: Crankshaft assembly width (A)	160 ± 0.1 mm (6.30 ± 0.004 in)

Crankshaft assembly width (F)	52 ⁺⁰ / _{-0.05} mm (2.047 ⁺⁰ / _{-0.002} in)
Crankshaft deflection (D)	0.03 mm (D-1) 0.04 mm (D-2) 0.04 mm (D-3) 0.03 mm (D-4)
Connecting rod large end side clearance (C)	0.25~0.35 mm (0.010~0.014 in)
Connecting rod small end deflection (P)	2.0 mm (0.079 in)

Crank pin outside diameter × length	φ22 × 51 mm (φ0.866 × 2.008 in)
Crank pin type	Solid shaft assembly type with serration
Crank bearing type (Left) × q'ty	#6306 special 1 pc.
Crank bearing type (Center) × q'ty	#6206 special × 2 pcs.
Crank bearing type (Right) × q'ty	#6305 special × 1 pc.
Crank oil seal type (Left) × q'ty	FPJ-30 72 8 2TS × 1 pc.
Crank oil seal type (Center) × q'ty	Labyrinth seal × 1 pc.
Crank oil seal type (Right) × q'ty	FPJ-25 48 8TS × 1 pc.

Carburetor:	
Type & manufacturer/quantity	B38-34 MIKUNI × 1 pc.
I.D. Mark	8J600
Main jet (M.J.)	#240
Pilot jet (P.J.)	#75
Pilot screw (P.S.)	1.0 turns out
Throttle valve (Th.V.)	#190
Valve seat (V.S.)	φ1.5 mm (0.059 in)
Float height	25 ± 1 mm (0.98 ± 0.04 in)
Idling engine speed	1700 r/min

Main jet setting chart

Altitude	Temperature					
	-30°C (-22°F)	-20°C (-4°F)	-10°C (14°F)	0°C (32°F)	10°C (50°F)	20°C (68°F)
Sea level	← #250 →		← #240 (Std) →		← #220 →	
~ 600m (2000 ft)	← #240 (Std) →		← #220 →			
~ 1200m (4000 ft)	← #240 (Std) →		← #220 →		← #210 *	
~ 1800m (6000 ft)	← #220 →		← #210 *		← #200 *	
~ 2400m (8000 ft)	← #210 →		← #200 →		← #190 →	
~ 3000m (10000 ft) or more	← #200 →		← #190 →			

* Newly changed specification.

Lubrication:	
Autolube pump — Color code	White
Autolube pump — Minimum stroke	0.20 ~ 0.25 mm (0.0079 ~ 0.0098 in)
Autolube pump — Maximum stroke	1.67 ~ 1.87 mm (0.0657 ~ 0.0736 in)
Autolube pump — Reduction ratio	1/32
Autolube pump — Output Min./200 strokes	0.50 ~ 0.63 cc (0.0169 ~ 0.0213 oz)
Autolube pump — Output Max./200 strokes	4.15 ~ 4.70 cc (0.1403 ~ 0.1589 oz)
Autolube pump wire free play	25 ± 1 mm (0.98 ± 0.04 in) at idle
Oil tank capacity	2.4 Liter (2.5 US.qt)
Oil grade	YAMALUBE 2-cycle

Drive and track suspension

Transmission:	
Type	V-belt automatic centrifugal engagement
Drive ratio	3.5 : 1 ~ 1 : 1
Engagement rpm	3000 r/min
Primary spring:	
Part No.	90501-50500
Color code	Red
Secondary spring:	
Part No.	90508-40080
Color code	No painted
Secondary spring pre-load (twist)	160°
Sheave distance	266 ± 2 mm (10.47 ± 0.08 in)
Sheave off-set	11 ± 1 mm (0.43 ± 0.04 in)
V-belt width and outer line length	31.6 × 1,099 mm (1.24 × 43.3 in)
V-belt wear limit	26 mm (1.02 in)
Track suspension:	
Type	Slide rail suspension
Damper type	Oil and gas damper
Spring color code (Front)	Red
Spring color code (Rear)	No painted
Slide runner wear limit	10 mm (0.394 in)
Track width	380 mm (15 in)
Track deflection	25 ~ 30 mm/10 kg (0.98 ~ 1.18 in/22 lb)
Length on ground	760 mm (29.9 in)
Wheel sprocket material and number of teeth	* Polyethylene 11T
Stopper band length	186.5 mm (7.34 in) (1st hole from the bottom)
Secondary drive:	
Type	Chain (#40K-2)
Reduction ratio	22/13 (1.692)
Chain pitch × Number of links	12.7 mm (0.5 in) × 60L
Free play	10 $\begin{smallmatrix} +5 \\ -2 \end{smallmatrix}$ mm (0.4 $\begin{smallmatrix} +0.2 \\ -0.08 \end{smallmatrix}$ in)
Chain housing oil quantity	400 cc (13.5 oz)
Chain housing oil grade	Gear oil API "GL3" (SAE #75 or 85)
Brake:	
Type	Disc brake
Brake pad thickness	7.3 mm (0.287 in)
Brake pad wear limit	1.0 mm (0.04 in)
Gap between pad and disc	0.2 ~ 1.0 mm (0.008 ~ 0.039 in)

Chassis

Frame: Material	Aluminum + Steel
Steering system: Caster (ski column) Camber Ski length X width X thickness Ski stance Ski toe-out Steering linkage type Lock to lock angle (Ski) Lock to lock angle (Steering column)	25° 0° 980 x 120 x 1.6 mm (38.6 x 4.7 x 0.06 in) 850 mm (33.5 in) 0 ~ 6 mm (0 ~ 0.23 mm) Tie-rod Right ski, L: 27.6° R: 24.8° Left ski, L: 24.8° R: 27.6° Right: 54.3° Left: 56.3°
Front suspension: Type Damper type	Leaf spring Oil damper
Fuel tank: Capacity Fuel grade	22.7 liter (6 US. gal) Regular gasoline

Electrical

Ignition system: Type—flywheel magneto (C.D.I. Type) Model/manufacturer Voltage Pulser coil resistance Charging coil resistance Charging coil resistance	F3T352/MITSUBISHI 12V 9.0Ω at 20°C (68°F) (White/Red—Black) 350Ω at 20°C (68°F) (Brown—Black) 15.0Ω at 20°C (68°F) (Blue—Black)
Ignition timing: B.T.D.C.	1.6 ± 0.1 mm (0.06 ± 0.004 in)
Ignition coil: Model/Manufacturer Spark gap Primary winding resistance Secondary winding resistance Diode (Yes or No)	CM62-20/HITACHI 9 mm (0.4 in)/300 r/min 11 mm (0.6 in)/3,000 r/min 0.15Ω at 20°C (68°F) 3.6kΩ at 20°C (68°F) No
Spark plug: Type & quantity Spark plug gap	* NGK BR-9ES x 2 pcs. 0.7~0.8 mm (0.028~0.031 in)
Spark plug cap: Type Noise suppressor resistance	Rubber type with noise suppressor 5kΩ at 20°C (68°F)
C.D.I. unit: Model/Manufacturer	8H4-20/MITSUBISHI
Starter motor type: Armature coil resistance Field coil resistance Brush length: standard minimum Brush spring pressure Armature mica undercut	* HITACHI S108-73 * 0.014Ω at 20°C (68°F) * 0.008Ω at 20°C (68°F) * 13.5 mm (0.53 in) * 9.5 mm (0.37 in) * 700 g (24.7 oz) * 0.2 mm (0.008 in)

Battery type: Charging rate Specific gravity	* YUASA YB-14L-2A * 1.4 Amps for 10 Hours 1.28/20°C (68°F)
Charging system Type * Charging coil resistance	Flywheel magneto 0.22Ω at 20°C (68°F) (White—Black)
Starter relay switch: Cut-in voltage Winding resistance	Hitachi A104-61 6.5V 3.0Ω at 20°C (68°F)
Rectifier: Type Model/manufacturer Capacity With stand voltage	1-element type (Half wave) DE5404/STANLEY 6A 400V
Lighting system: Lighting output Lighting coil resistance Head light type Bulb wattage/q'ty Tail/brake light wattage	* 12V-110W 0.19Ω at 20°C (68°F) (Yellow—Black) Semi shield 12V-60/60W × 1 pc. 12V-8W/23W
A.C. regulator: Model/Manufacturer Voltage	TRIZ-24B/HITACHI or S8516B/TOSHIBA 13.8 ± 0.5V

Tightening torque

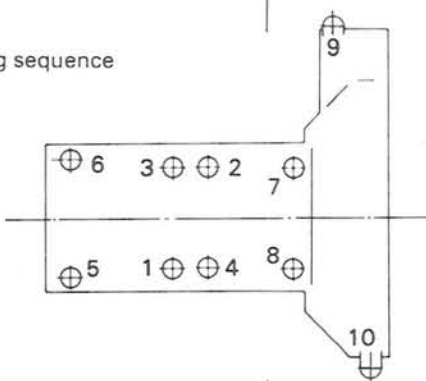
Part to be tightened	Thread size	Tightening torque	Remarks
Engine:			
Spark plug	M14 P1.25	2.8 m-kG (20 ft-lb)	
Cylinder head	M8 P1.25	2.5 m-kG (18 ft-lb)	
Flywheel magneto	M16 P1.0	7.3 m-kG (53 ft-lb)	
Crankcase upper and lower	M8 P1.25	First: 1.0 m-kG (7.5 ft-lb) Final: 2.0 m-kG (15 ft-lb)	
 <p>Tightening sequence</p>			
Starter pulley	M8 P1.25	1.6 m-kG (11.5 ft-lb)	
Crankcase and Engine bracket	M10 P1.25	3.0 m-kG (21.5 ft-lb)	

Drive and track suspension:				
Primary sliding sheave and Cap	M6	P1.0	1.1 m-kg (8 ft-lb)	Use Motor oil
Installation of primary sheave	UNF1/2"		Initial: 12 m-kg (88 ft-lb)	
			Loosen once and retighten:	
			6.0 m-kg (43.5 ft-lb)	
Installation of drive chain sprocket	M12	P1.25	4.0 m-kg (29 ft-lb)	Use cotter pin
Installation of driven chain sprocket	M10	P1.25	3.5 m-kg (25 ft-lb)	
Chain housing and Frame	M8	P1.25	2.5 m-kg (18 ft-lb)	
Chain housing cap	M8	P1.25	1.6 m-kg (11.5 ft-lb)	
Chain tensioner lock nut	M10	P1.25	3.3 m-kg (24 ft-lb)	
Installation of front axle R.H.	M20	P1.0	9.0 m-kg (65 ft-lb)	
Front axle housing and Frame	M8	P1.25	2.5 m-kg (18 ft-lb)	
Wheel sprocket and Front axle			0.5 m-kg (3.5 ft-lb)	
Shaft 1 and Frame	M10	P1.25	5.5 m-kg (40 ft-lb)	Use LOCK-TITE
Shaft 2 and Rear bracket	M10	P1.25	5.5 m-kg (40 ft-lb)	Use LOCK-TITE
Rear bracket and Frame	M8	P1.25	2.5 m-kg (18 ft-lb)	Use LOCK-TITE
Bracket 2 and Frame sliding 1	M6	P1.0	1.2 m-kg (9 ft-lb)	
Installation of suspension wheel	M6	P1.0	1.1 m-kg (8 ft-lb)	
Installation of rear guide wheel	M8	P1.25	2.5 m-kg (18 ft-lb)	Use LOCK-TITE
Installation of runner sliding 1	M6	P1.0	0.25 m-kg (2 ft-lb)	Use LOCK-TITE
Installation of runner sliding 2	M6	P1.0	0.6 m-kg (4 ft-lb)	Use LOCK-TITE
Pivot arm 1 and Bracket 2	M6	P1.0	5.0 m-kg (36 ft-lb)	Use LOCK-TITE
Pivot 5 & 6 and Frame sliding 1	M6	P1.0	1.3 m-kg (9.5 ft-lb)	Use LOCK-TITE
Frame sliding 1 and 2 & 3	M8	P1.25	2.5 m-kg (18 ft-lb)	
Installation of stopper 1	M6	P1.0	0.35 m-kg (2.5 ft-lb)	
Chassis:				
Engine mounting bolt	M10	P1.25	3.0 m-kg (22 ft-lb)	
Ski runner	M8	P1.25	1.4 m-kg (10 ft-lb)	Use plain washer and LOCK-TITE
Steering column and Gate	M8	P1.25	2.0 m-kg (14.5 ft-lb)	Use lock washer
Steering relay rod adjusting nut	M10	P1.25	2.5 m-kg (18 ft-lb)	
Out side arm and Ski column	M10	P1.25	3.0 m-kg (22 ft-lb)	Use lock washer and wave washer
Steering lower bracket	M8	P1.25	2.0 m-kg (14.5 ft-lb)	Use lock washer and LOCK-TITE
Installation of steering column 1, 2	M8	P1.25	1.45 m-kg (10.5 ft-lb)	Use lock washer
Steering relay ass'y	M10	P1.25	3.0 m-kg (22 ft-lb)	Use cotter pin
Universal joint	M10	P1.25	2.5 m-kg (18 ft-lb)	
Steering gate	M8	P1.25	1.4 m-kg (10 ft-lb)	

4. SPECIAL TOOLS

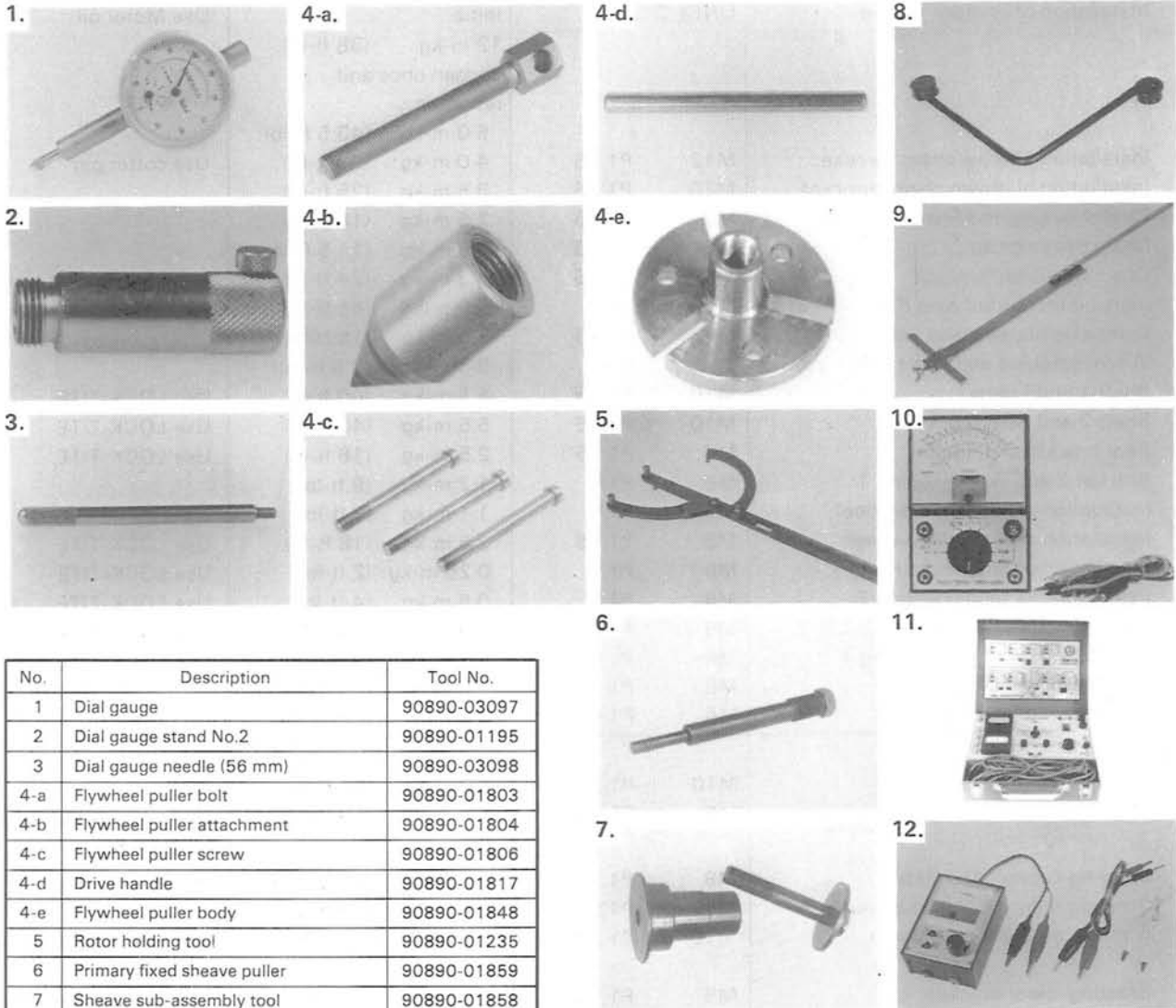

No.	Description	Tool No.
1	Dial gauge	90890-03097
2	Dial gauge stand No.2	90890-01195
3	Dial gauge needle (56 mm)	90890-03098
4-a	Flywheel puller bolt	90890-01803
4-b	Flywheel puller attachment	90890-01804
4-c	Flywheel puller screw	90890-01806
4-d	Drive handle	90890-01817
4-e	Flywheel puller body	90890-01848
5	Rotor holding tool	90890-01235
6	Primary fixed sheave puller	90890-01859
7	Sheave sub-assembly tool	90890-01858
8	Bushing tool	90890-01877
9	Sheave gauge	90890-01875
10	Pocket tester	90890-03104
11	Electro tester	90890-03021
12	A.C. Regulator checker	90890-03090

5. WIRING DIAGRAM

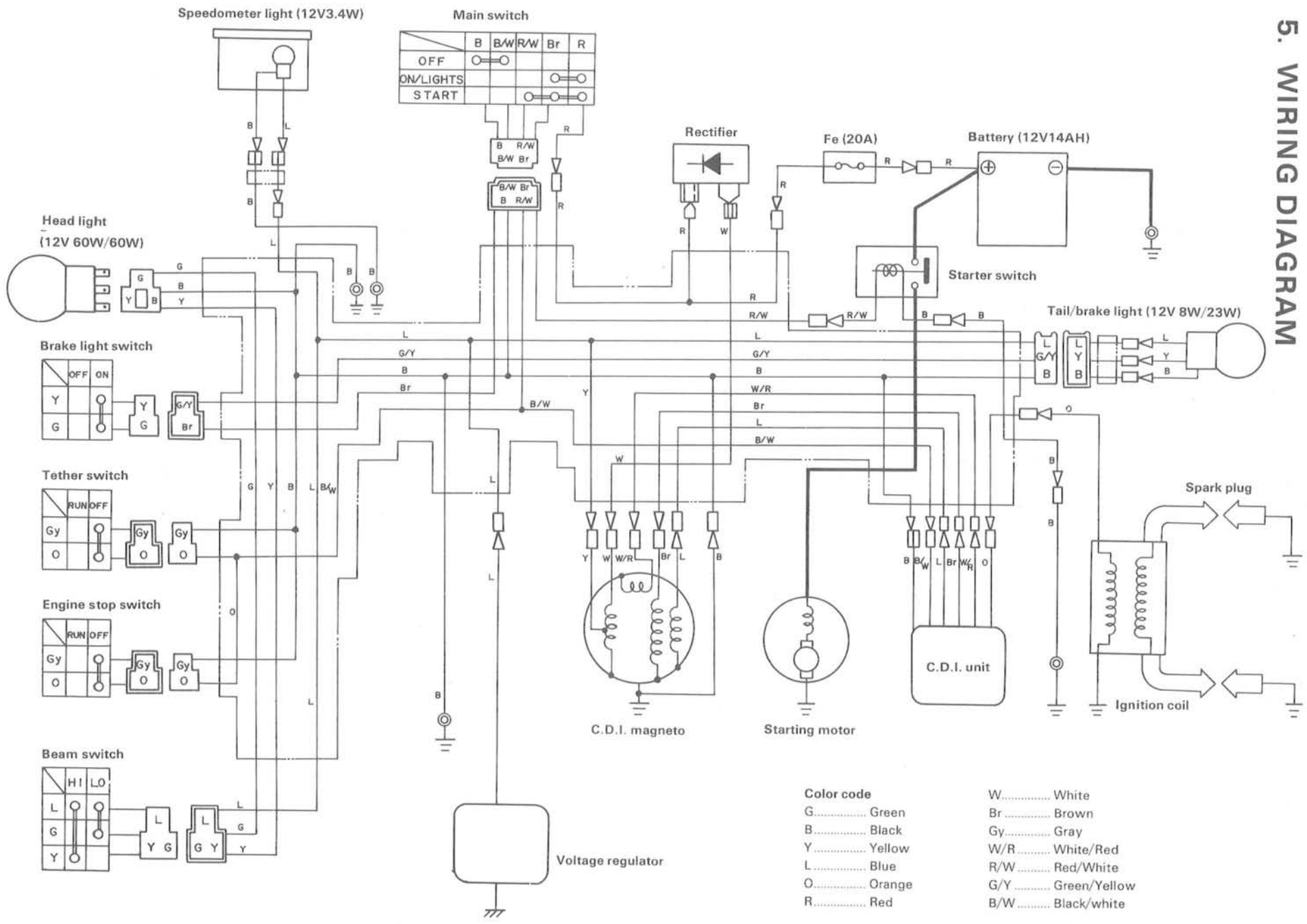

— MEMO —

